

# GripTight MAX<sup>®</sup> Test Plug Technical Specifications

## Thank you for choosing to use a GripTight MAX (GTMAX<sup>®</sup>) Test Plug.

Proper maintenance of your GripTight MAX Test Plugs should always include lubrication of the shaft threads where the Hex Nut(s) is/are installed and both sides of the Hardened Washer(s) with antiseize, as well as lubrication of the tapered surface of the cone with an appropriate lubricant such as Molykote<sup>®</sup> DX paste. Ensure the Seal, Gripper Teeth, and the inside of the unit under test are not exposed to any lubricant.

### WARNING

- ⚠ GTMAX plugs are for use in all Carbon Steel, Stainless Steel and Alloy pipes with a hardness up to HRC 32. Contact EST Customer Service if pipes to be tested have a hardness greater than HRC 32.
- ⚠ Contact EST Group Customer Service if the test pressure required exceeds the maximum plug rating or is in excess of 80% of specified minimum yield stress for host pipe, tube, or equipment.
- ⚠ Pressure testing is inherently dangerous. Strict adherence to the operating procedures and industry standard safety practices could prevent injury to personnel and damage to equipment.
- ⚠ All personnel must be clear of the GripTight MAX Test Plug during pressure testing. Never stand in the potential path of a GripTight MAX Test Plug during testing. Always understand and observe industry standard safe practices for distance between personnel and equipment being tested.
- ⚠ Pressures must never exceed the maximum pressure rating of any component in a system or the maximum pressure rating of the GripTight MAX Test Plug being used.
- ⚠ For safety, an incompressible liquid such as water should be used as the test medium. Residual air or gas should be displaced or vented from the pipe prior to testing.
- ⚠ If testing pneumatically, every attempt to limit potential damage to equipment or injury to personnel must be made. Testing procedures and protocol should adhere to the provisions for pneumatic testing set forth in the current ASME PCC-2 Repair of Pressure Equipment and Piping.

**Questions?** Contact EST Group Customer Service at any of the following locations.

**CURTISS -  
WRIGHT**

EST Group

[www.cw-estgroup.com](http://www.cw-estgroup.com)**North, Central & South America**

**EST Group Corporate Office**  
2701 Township Line Road  
Hatfield, PA 19440-1770 USA  
P: +1.215.721.1100  
+1.800.355.7044  
F: +1.215.721.1101  
[est-info@curtisswright.com](mailto:est-info@curtisswright.com)

**Europe / Middle East / Africa**

**EST Group B.V.**  
Hoorn 312a  
2404 HL Alphen aan den Rijn  
The Netherlands  
P: +31.172.418841  
F: +31.172.418849  
[est-emea@curtisswright.com](mailto:est-emea@curtisswright.com)

**China**

P +86.400.636.5077  
[est-china@curtisswright.cn](mailto:est-china@curtisswright.cn)

**Singapore**

P +65.3158.5052  
[est-asia@curtisswright.com](mailto:est-asia@curtisswright.com)

# GripTight MAX<sup>®</sup> Test Plug Technical Specifications

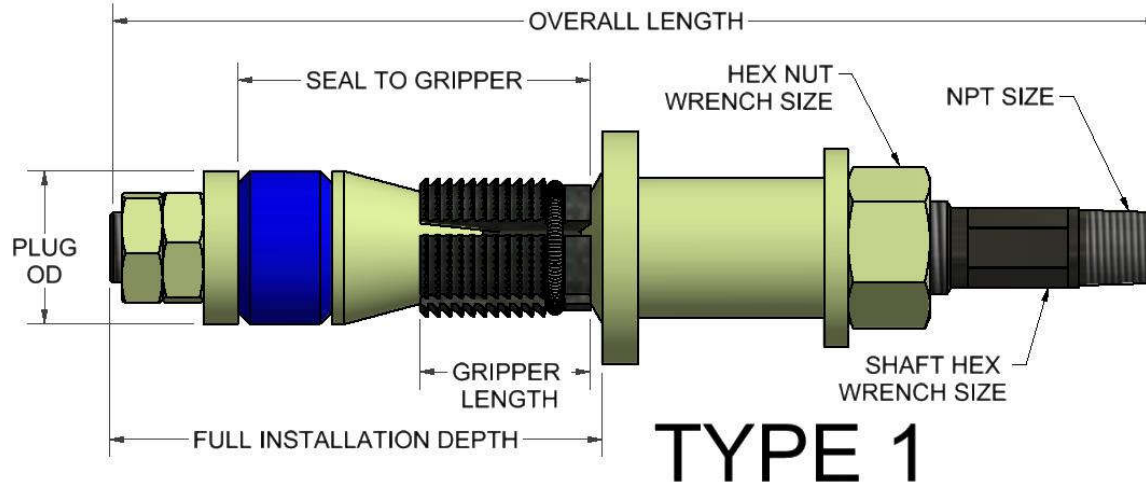

Sales Number	Nominal Pipe Size	Pipe Schedule	Type	Functional I.D. Range		Plug OD		Total clearance from Min. I.D.		NPT Size	Shaft / Port I.D.		Approximate Weight		Overall Length		Seal to Gripper		Gripper Length		Full Installation Depth		Maximum Test Pressure		Shaft Hex Wrench Size (in)	Hex Nut Wrench Size (in)
				(in)	(mm)	(in)	(mm)	(in)	(mm)		(in)	(mm)	(lbs)	(kg)	(in)	(mm)	(in)	(mm)	(in)	(mm)	(PsiG)	(BarG)				
				Min - Max	Min - Max	-	-	-	-		-	-	-	-	-	-	-	-	-	-	-	-	-	-		
GTMAX-038P40	3/8	40	1	0.48 - 0.52	12.2 - 13.2	0.46	11.7	0.02	0.5	1/8	0.11	2.8	1/2	1/4	5.31	134.9	1.29	32.9	0.55	14.1	1.85	47.0	15000	1034	3/8	3/4
GTMAX-050P10	1/2	10	1	0.63 - 0.69	16.0 - 17.5	0.60	15.2	0.03	0.8	1/8	0.11	2.8	1/2	1/4	5.31	134.9	1.67	42.3	0.80	20.2	2.27	57.7	15000	1034	3/8	3/4
GTMAX-050P40	1/2	40	1	0.57 - 0.63	14.5 - 16.0	0.54	13.7	0.03	0.8	1/8	0.11	2.8	1/2	1/4	5.31	134.9	1.48	37.7	0.68	17.2	2.07	52.6	15000	1034	3/8	3/4
GTMAX-050P80	1/2	80	1	0.52 - 0.57	13.2 - 14.5	0.49	12.4	0.03	0.8	1/8	0.11	2.8	1/2	1/4	5.31	134.9	1.41	35.7	0.62	15.7	1.98	50.2	15000	1034	3/8	3/4
GTMAX-050P160	1/2	160	1	0.48 - 0.52	12.2 - 13.2	0.46	11.7	0.02	0.5	1/8	0.11	2.8	1/2	1/4	5.31	134.9	1.29	32.9	0.55	14.1	1.85	47.0	15000	1034	3/8	3/4
GTMAX-075P10	3/4	10	1	0.85 - 0.93	21.6 - 23.6	0.82	20.8	0.03	0.8	1/8	0.13	3.2	1/2	1/4	5.63	142.9	1.86	47.3	0.98	24.9	2.63	66.7	15000	1034	3/8	3/4
GTMAX-075P40	3/4	40	1	0.77 - 0.85	19.6 - 21.6	0.74	18.8	0.03	0.8	1/8	0.13	3.2	1/2	1/4	5.63	142.9	1.81	46.1	0.98	24.9	2.55	64.9	15000	1034	3/8	3/4
GTMAX-075P80	3/4	80	1	0.69 - 0.77	17.5 - 19.6	0.66	16.8	0.03	0.8	1/8	0.11	2.8	1/2	1/4	5.31	134.9	1.76	44.6	0.92	23.3	2.38	60.5	15000	1034	3/8	3/4
GTMAX-075P160	3/4	160	1	0.57 - 0.63	14.5 - 16.0	0.54	13.7	0.03	0.8	1/8	0.11	2.8	1/2	1/4	5.31	134.9	1.48	37.7	0.68	17.2	2.07	52.6	15000	1034	3/8	3/4
GTMAX-1P5	1	5	2	1.13 - 1.24	28.7 - 31.5	1.07	27.2	0.06	1.5	1/4	0.31	8.0	1	1/2	6.63	168.3	2.25	57.2	0.93	23.6	3.58	90.9	15000	1034	1/2	15/16
GTMAX-1P10	1	10	2	1.07 - 1.20	27.2 - 30.5	1.03	26.2	0.04	1.0	1/8	0.12	3.1	3/4	1/4	6.00	152.4	2.31	58.6	0.80	20.3	3.57	90.8	15000	1034	3/8	3/4
GTMAX-1P40	1	40 / STD	2	1.01 - 1.09	25.7 - 27.7	0.97	24.6	0.04	1.0	1/8	0.13	3.2	3/4	1/4	6.00	152.4	2.12	53.9	0.80	20.3	3.39	86.0	15000	1034	3/8	3/4
GTMAX-1P80	1	80 / XS	2	0.93 - 1.00	23.6 - 25.4	0.89	22.6	0.04	1.0	1/8	0.13	3.2	3/4	1/4	6.00	152.4	2.05	52.0	0.80	20.3	3.31	84.1	15000	1034	3/8	3/4
GTMAX-1P160	1	160	1	0.77 - 0.85	19.6 - 21.6	0.74	18.8	0.03	0.8	1/8	0.13	3.2	1/2	1/4	5.63	142.9	1.81	46.1	0.98	24.9	2.55	64.9	15000	1034	3/8	3/4
GTMAX-1PXXS	1	XXS	1	0.57 - 0.63	14.5 - 16.0	0.54	13.7	0.03	0.8	1/8	0.11	2.8	1/2	1/4	5.31	134.9	1.48	37.7	0.68	17.2	2.07	52.6	15000	1034	3/8	3/4

Questions? Contact EST Group Customer Service at any of the following locations.



EST Group  
[www.cw-estgroup.com](http://www.cw-estgroup.com)

**North, Central & South America**  
EST Group Corporate Office  
2701 Township Line Road  
Hatfield, PA 19440-1770 USA  
P: +1.215.721.1100  
+1.800.355.7044  
F: +1.215.721.1101  
[est-info@curtisswright.com](mailto:est-info@curtisswright.com)

**Europe / Middle East / Africa**  
EST Group B.V.  
Hoorn 312a  
2404 HL Alphen aan den Rijn  
The Netherlands  
P: +31.172.418841  
F: +31.172.418849  
[est-emea@curtisswright.com](mailto:est-emea@curtisswright.com)

**China**  
P +86.400.636.5077  
[est-china@curtisswright.cn](mailto:est-china@curtisswright.cn)

**Singapore**  
P +65.3158.5052  
[est-asia@curtisswright.com](mailto:est-asia@curtisswright.com)

# GripTight MAX<sup>®</sup> Test Plug Technical Specifications

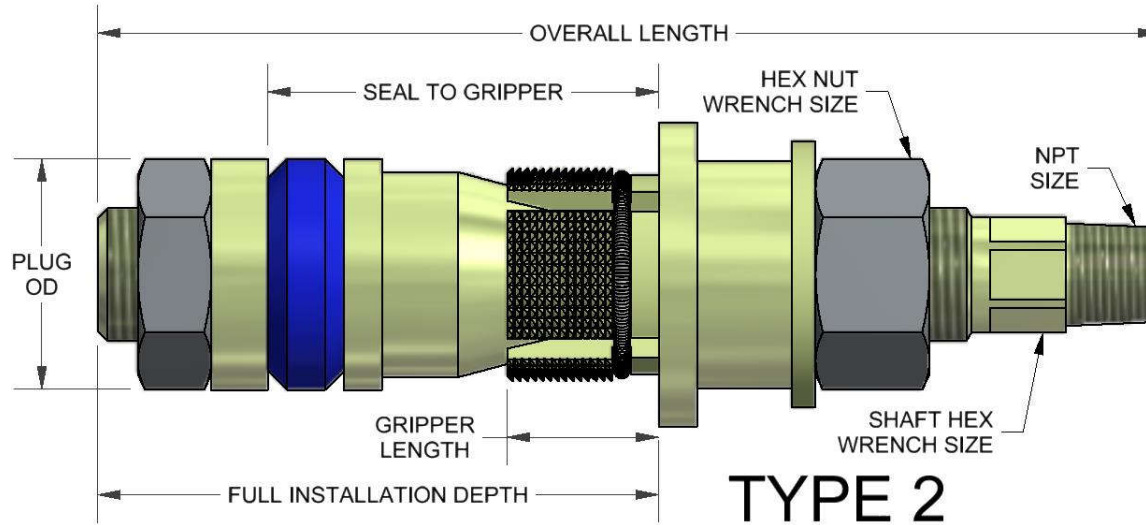

**TYPE 2**

Sales Number	Nominal Pipe Size	Pipe Schedule	Type	Functional I.D. Range		Plug OD		Total clearance from Min. I.D.		NPT Size	Shaft / Port I.D.		Approximate Weight		Overall Length		Seal to Gripper		Gripper Length		Full Installation Depth		Maximum Test Pressure		Shaft Hex Wrench Size	Hex Nut Wrench Size
				(in)	(mm)																					
				Min - Max	Min - Max	(in)	(mm)	(in)	(mm)	(in)	(mm)	(in)	(mm)	(lbs)	(kg)	(in)	(mm)	(in)	(mm)	(in)	(mm)	(PsiG)	(BarG)	(in)	(in)	
GTMAX-125P5	1 1/4	5	2	1.47 - 1.61	37.3 - 40.9	1.41	35.8	0.06	1.5	3/8	0.44	11.1	2 1/4	1	7.00	177.8	2.26	57.4	1.00	25.4	3.79	96.2	15000	1034	11/16	1 - 5/16
GTMAX-125P10	1 1/4	10	2	1.41 - 1.49	35.8 - 37.8	1.35	34.3	0.06	1.5	3/8	0.44	11.1	2 1/4	1	7.00	177.8	2.45	62.2	1.00	25.4	3.97	100.9	15000	1034	11/16	1 - 5/16
GTMAX-125P40	1 1/4	40 / STD	2	1.31 - 1.43	33.3 - 36.3	1.25	31.8	0.06	1.5	1/4	0.31	8.0	1 1/4	1/2	6.63	168.3	2.25	57.2	0.93	23.6	3.58	90.9	15000	1034	1/2	15/16
GTMAX-125P80	1 1/4	80 / XS	2	1.25 - 1.33	31.8 - 33.8	1.19	30.2	0.06	1.5	1/4	0.31	8.0	1 1/4	1/2	6.63	168.3	2.25	57.2	0.93	23.6	3.58	90.9	15000	1034	1/2	15/16
GTMAX-125P160	1 1/4	160	2	1.13 - 1.24	28.7 - 31.5	1.07	27.2	0.06	1.5	1/4	0.31	8.0	1	1/2	6.63	168.3	2.25	57.2	0.93	23.6	3.58	90.9	15000	1034	1/2	15/16
GTMAX-15P5	1 1/2	5	2	1.74 - 1.91	44.2 - 48.5	1.68	42.7	0.06	1.5	3/8	0.44	11.1	2 1/2	1 1/4	7.00	177.8	2.16	55.0	1.00	25.4	3.69	93.7	15000	1034	11/16	1 - 5/16
GTMAX-15P10	1 1/2	10	2	1.66 - 1.77	42.2 - 45.0	1.60	40.6	0.06	1.5	3/8	0.44	11.1	2 1/2	1 1/4	7.00	177.8	2.56	65.0	1.00	25.4	4.08	103.8	15000	1034	11/16	1 - 5/16
GTMAX-15P40	1 1/2	40 / STD	2	1.58 - 1.66	40.1 - 42.2	1.52	38.6	0.06	1.5	3/8	0.44	11.1	2 1/4	1	7.00	177.8	2.41	61.2	1.00	25.4	3.94	100.0	15000	1034	11/16	1 - 5/16
GTMAX-15P80	1 1/2	80	2	1.47 - 1.61	37.3 - 40.9	1.41	35.8	0.06	1.5	3/8	0.44	11.1	2 1/4	1	7.00	177.8	2.26	57.4	1.00	25.4	3.79	96.2	15000	1034	11/16	1 - 5/16
GTMAX-15P160	1 1/2	160	2	1.31 - 1.43	33.3 - 36.3	1.25	31.8	0.06	1.5	1/4	0.31	8.0	1 1/4	1/2	6.63	168.3	2.25	57.2	0.93	23.6	3.58	90.9	15000	1034	1/2	15/16
GTMAX-15PXXS	1 1/2	XXS	2	1.07 - 1.20	27.2 - 30.5	1.03	26.2	0.04	1.0	1/8	0.12	3.1	3/4	1/4	6.00	152.4	2.31	58.6	0.80	20.3	3.57	90.8	15000	1034	3/8	3/4
GTMAX-2P5	2	5	2	2.22 - 2.30	56.4 - 58.4	2.12	53.8	0.10	2.5	3/8	0.44	11.1	3 1/2	1 1/2	7.00	177.8	2.04	51.8	1.02	25.9	3.56	90.5	12000	827	11/16	1 - 5/16
GTMAX-2P10	2	10	2	2.10 - 2.22	53.3 - 56.4	2.00	50.8	0.10	2.5	3/8	0.44	11.1	3 1/2	1 1/2	7.00	177.8	2.09	53.2	1.02	25.9	3.62	91.9	12000	827	11/16	1 - 5/16
GTMAX-2P40	2	40 / STD	2	2.04 - 2.12	51.8 - 53.8	1.94	49.3	0.10	2.5	3/8	0.44	11.1	2 3/4	1 1/4	7.00	177.8	2.04	51.8	1.02	25.9	3.56	90.5	12000	827	11/16	1 - 5/16
GTMAX-198T			2	1.98 - 2.06	50.3 - 52.3	1.88	47.8	0.10	2.5	3/8	0.44	11.1	3	1 1/4	7.00	177.8	2.04	51.8	1.02	25.9	3.56	90.5	12000	827	11/16	1 - 5/16
GTMAX-2P80	2	80 / XS	2	1.91 - 1.99	48.5 - 50.5	1.81	46.0	0.10	2.5	3/8	0.44	11.1	2 1/2	1 1/4	7.00	177.8	2.04	51.8	1.02	25.9	3.56	90.5	12000	827	11/16	1 - 5/16
GTMAX-2P160	2	160	2	1.66 - 1.77	42.2 - 45.0	1.60	40.6	0.06	1.5	3/8	0.44	11.1	2 1/2	1 1/4	7.00	177.8	2.56	65.0	1.00	25.4	4.08	103.8	15000	1034	11/16	1 - 5/16
GTMAX-2PXXS	2	XXS	2	1.47 - 1.61	37.3 - 40.9	1.41	35.8	0.06	1.5	3/8	0.44	11.1	2 1/4	1	7.00	177.8	2.26	57.4	1.00	25.4	3.79	96.2	15000	1034	11/16	1 - 5/16

Questions? Contact EST Group Customer Service at any of the following locations.



EST Group  
[www.cw-estgroup.com](http://www.cw-estgroup.com)

**North, Central & South America**  
EST Group Corporate Office  
2701 Township Line Road  
Hatfield, PA 19440-1770 USA  
P: +1.215.721.1100  
+1.800.355.7044  
F: +1.215.721.1101  
[est-info@curtisswright.com](mailto:est-info@curtisswright.com)

**Europe / Middle East / Africa**  
EST Group B.V.  
Hoorn 312a  
2404 HL Alphen aan den Rijn  
The Netherlands  
P: +31.172.418841  
F: +31.172.418849  
[est-emea@curtisswright.com](mailto:est-emea@curtisswright.com)

**China**  
P +86.400.636.5077  
[est-china@curtisswright.cn](mailto:est-china@curtisswright.cn)

**Singapore**  
P +65.3158.5052  
[est-asia@curtisswright.com](mailto:est-asia@curtisswright.com)

# GripTight MAX<sup>®</sup> Test Plug Technical Specifications

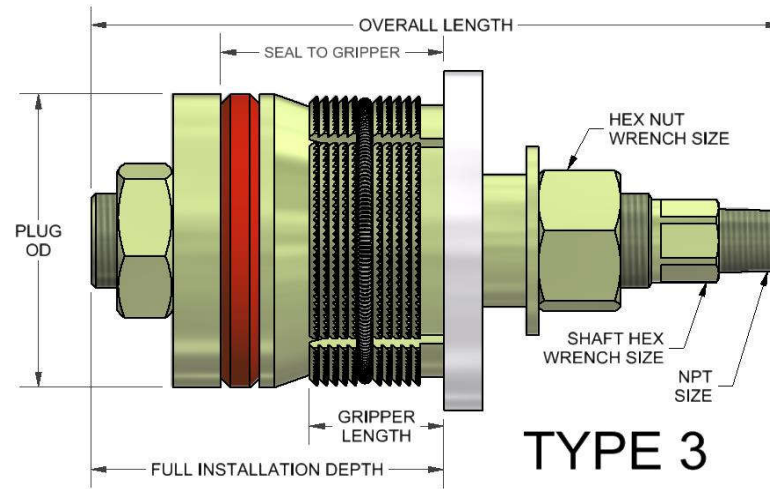

**TYPE 3**

Sales Number	Nominal Pipe Size	Pipe Schedule	Type	Functional I.D. Range		Plug OD		Total clearance from Min. I.D.		NPT Size	Shaft / Port I.D.		Approximate Weight		Overall Length		Seal to Gripper		Gripper Length		Full Installation Depth		Maximum Test Pressure		Shaft Hex Wrench Size	Hex Nut Wrench Size
				(in)	(mm)																					
				Min - Max	Min - Max	(in)	(mm)	(in)	(mm)	(in)	(mm)	(in)	(mm)	(lbs)	(kg)	(in)	(mm)	(in)	(mm)	(in)	(mm)	(in)	(mm)	(PsiG)	(BarG)	(in)
GTMAX-25P5	2 1/2	5	3	2.68 - 2.78	68.1 - 70.6	2.58	65.5	0.10	2.5	1/2	0.56	14.3	7	3 1/4	8.94	227.0	2.19	55.6	1.17	29.7	4.49	114.2	12000	827	1	1 - 7/8
GTMAX-25P10	2 1/2	10	3	2.60 - 2.74	66.0 - 69.6	2.50	63.5	0.10	2.5	1/2	0.56	14.3	6 3/4	3	8.94	227.0	2.42	61.6	1.35	34.3	4.73	120.1	12000	827	1	1 - 7/8
GTMAX-253T			3	2.53 - 2.63	64.3 - 66.8	2.43	61.7	0.10	2.5	1/2	0.56	14.3	6	2 3/4	8.94	227.0	2.22	56.3	1.17	29.7	4.52	114.9	12000	827	1	1 - 7/8
GTMAX-25P40	2 1/2	40 / STD	3	2.44 - 2.54	62.0 - 64.5	2.34	59.4	0.10	2.5	1/2	0.56	14.3	6	2 3/4	8.94	227.0	2.19	55.6	1.17	29.7	4.49	114.2	12000	827	1	1 - 7/8
GTMAX-25P80	2 1/2	80 / XS	2	2.27 - 2.45	57.7 - 62.2	2.17	55.1	0.10	2.5	3/8	0.44	11.1	3 1/2	1 1/2	7.00	177.8	2.04	51.8	1.02	25.9	3.56	90.5	12000	827	11/16	1 - 5/16
GTMAX-25P160	2 1/2	160	2	2.10 - 2.22	53.3 - 56.4	2.00	50.8	0.10	2.5	3/8	0.44	11.1	3 1/2	1 1/2	7.00	177.8	2.09	53.2	1.02	25.9	3.62	91.9	12000	827	11/16	1 - 5/16
GTMAX-25PXXS	2 1/2	XXS	2	1.74 - 1.91	44.2 - 48.5	1.68	42.7	0.06	1.5	3/8	0.44	11.1	2 1/2	1 1/4	7.00	177.8	2.16	55.0	1.00	25.4	3.69	93.7	15000	1034	11/16	1 - 5/16
GTMAX-3P5	3	5	3	3.30 - 3.41	83.8 - 86.6	3.20	81.3	0.10	2.5	1/2	0.56	14.3	8 1/2	3 3/4	8.94	227.0	2.62	66.5	1.57	39.9	4.92	125.0	12000	827	1	1 - 7/8
GTMAX-3P10	3	10	3	3.23 - 3.34	82.0 - 84.8	3.13	79.5	0.10	2.5	1/2	0.56	14.3	8 1/4	3 3/4	8.94	227.0	2.62	66.5	1.57	39.9	4.92	125.0	12000	827	1	1 - 7/8
GTMAX-3P40	3	40 / STD	3	3.04 - 3.14	77.2 - 79.8	2.94	74.7	0.10	2.5	1/2	0.56	14.3	8	3 1/2	8.94	227.0	2.41	61.1	1.36	34.5	4.71	119.7	12000	827	1	1 - 7/8
GTMAX-296T			3	2.96 - 3.07	75.2 - 78.0	2.86	72.6	0.10	2.5	1/2	0.56	14.3	7 1/2	3 1/2	8.94	227.0	2.41	61.1	1.36	34.5	4.71	119.7	12000	827	1	1 - 7/8
GTMAX-3P80	3	80 / XS	3	2.87 - 2.98	72.9 - 75.7	2.77	70.4	0.10	2.5	1/2	0.56	14.3	7 1/2	3 1/2	8.94	227.0	2.41	61.1	1.36	34.5	4.71	119.7	12000	827	1	1 - 7/8
GTMAX-3P160	3	160	3	2.60 - 2.74	66.0 - 69.6	2.50	63.5	0.10	2.5	1/2	0.56	14.3	6 3/4	3	7.00	177.8	2.04	51.8	1.02	25.9	3.56	90.5	12000	827	1	1 - 7/8
GTMAX-3PXXS	3	XXS	2	2.27 - 2.45	57.7 - 62.2	2.17	55.1	0.10	2.5	3/8	0.44	11.1	3 1/2	1 1/2	7.00	177.8	2.04	51.8	1.02	25.9	3.56	90.5	12000	827	11/16	1 - 5/16
GTMAX-35P5	3 1/2	5	3	3.80 - 3.91	96.5 - 99.3	3.70	94.0	0.10	2.5	1/2	0.56	14.3	11	5	8.94	227.0	2.79	70.8	1.74	44.2	5.09	129.3	10000	689	1	1 - 7/8
GTMAX-35P10	3 1/2	10	3	3.73 - 3.84	94.7 - 97.5	3.63	92.2	0.10	2.5	1/2	0.56	14.3	10 1/2	4 3/4	8.94	227.0	2.67	67.7	1.62	41.1	4.97	126.3	10000	689	1	1 - 7/8
GTMAX-35P40	3 1/2	40 / STD	3	3.52 - 3.63	89.4 - 92.2	3.42	86.9	0.10	2.5	1/2	0.56	14.3	9 1/2	4 1/4	8.94	227.0	2.67	67.7	1.62	41.1	4.97	126.3	10000	689	1	1 - 7/8
GTMAX-35P80	3 1/2	80 / XS	3	3.33 - 3.44	84.6 - 87.4	3.23	82.0	0.10	2.5	1/2	0.56	14.3	8 3/4	4	8.94	227.0	2.71	68.8	1.66	42.2	5.01	127.3	10000	689	1	1 - 7/8
GTMAX-35PXXS	3 1/2	XXS	3	2.70 - 2.89	68.6 - 73.4	2.60	66.0	0.10	2.5	1/2	0.56	14.3	7 1/2	3 1/2	8.94	227.0	2.62	66.5	1.46	37.1	4.92	125.0	10000	689	1	1 - 7/8

Questions? Contact EST Group Customer Service at any of the following locations.



EST Group

[www.cw-estgroup.com](http://www.cw-estgroup.com)

North, Central & South America

EST Group Corporate Office  
2701 Township Line Road  
Hatfield, PA 19440-1770 USA  
P: +1.215.721.1100  
+1.800.355.7044  
F: +1.215.721.1101  
[est-info@curtisswright.com](mailto:est-info@curtisswright.com)

Europe / Middle East / Africa

EST Group B.V.  
Hoorn 312a  
2404 HL Alphen aan den Rijn  
The Netherlands  
P: +31.172.418841  
F: +31.172.418849  
[est-emea@curtisswright.com](mailto:est-emea@curtisswright.com)

China

P +86.400.636.5077  
[est-china@curtisswright.cn](mailto:est-china@curtisswright.cn)

Singapore

P +65.3158.5052  
[est-asia@curtisswright.com](mailto:est-asia@curtisswright.com)

# GripTight MAX<sup>®</sup> Test Plug Technical Specifications

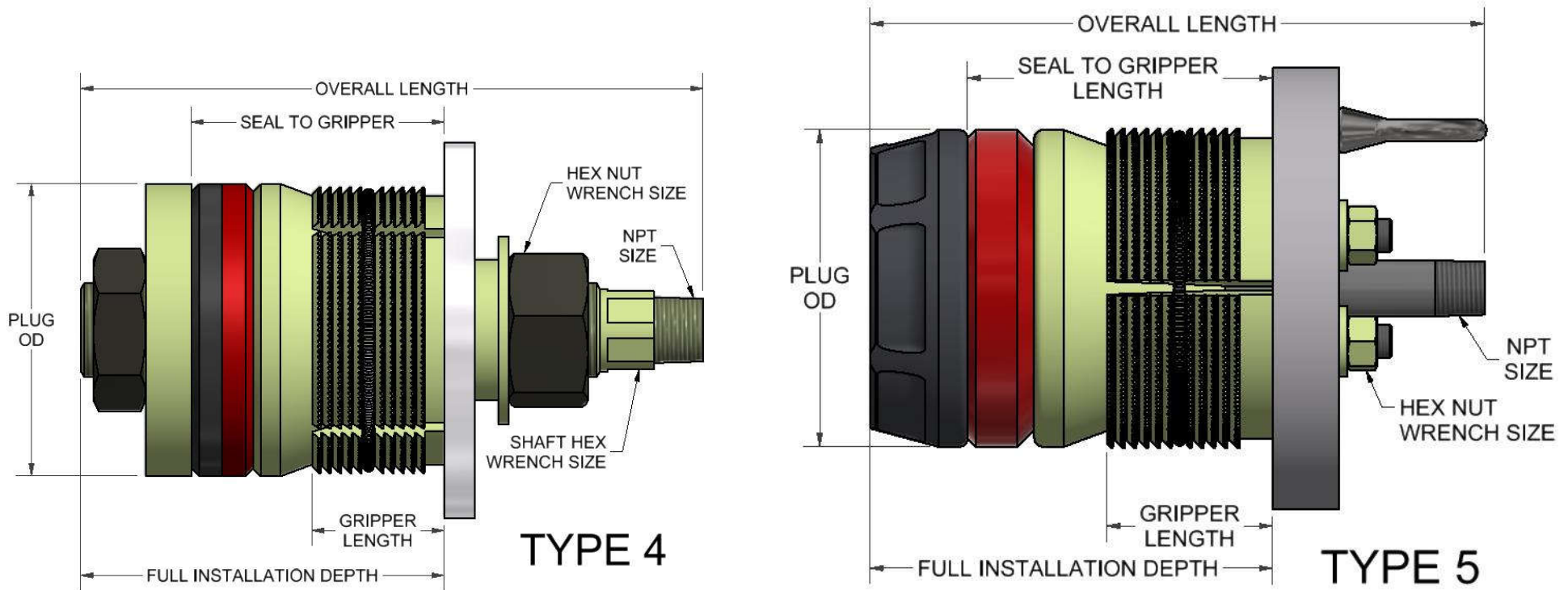

Sales Number	Nominal Pipe Size	Pipe Schedule	Type	Functional I.D. Range		Plug OD		Total clearance from Min. I.D.		NPT Size	Shaft / Port I.D.		Approximate Weight		Overall Length		Seal to Gripper		Gripper Length		Full Installation Depth		Maximum Test Pressure		Shaft Hex Wrench Size (in)	Hex Nut Wrench Size (in)
				Min - Max (in)	Min - Max (mm)	(in)	(mm)	(in)	(mm)		(in)	(mm)	(lbs)	(kg)	(in)	(mm)	(in)	(mm)	(in)	(mm)	(PsiG)	(BarG)				
GTMAX-4P5	4	5	4	4.28 - 4.47	108.7 - 113.5	4.17	105.9	0.11	2.8	3/4	0.75	19.1	18	8 1/4	10.13	257.2	3.56	90.3	2.15	54.6	6.17	156.6	10000	689	1 - 1/4	2 - 1/4
GTMAX-4P10	4	10	3	4.23 - 4.34	107.4 - 110.2	4.12	104.6	0.11	2.8	1/2	0.56	14.3	13	6	8.94	227.0	2.81	71.5	1.74	44.2	5.12	130.0	10000	689	1	1 - 7/8
GTMAX-4P40	4	40 / STD	3	4.00 - 4.11	101.6 - 104.4	3.89	98.8	0.11	2.8	1/2	0.56	14.3	12	5 1/2	8.94	227.0	2.81	71.5	1.74	44.2	5.12	130.0	10000	689	1	1 - 7/8
GTMAX-390T			3	3.90 - 4.01	99.1 - 101.9	3.79	96.3	0.11	2.8	1/2	0.56	14.3	12	5 1/2	8.94	227.0	2.81	71.5	1.74	44.2	5.12	130.0	10000	689	1	1 - 7/8
GTMAX-4P80	4	80 / XS	3	3.80 - 3.91	96.5 - 99.3	3.70	94.0	0.10	2.5	1/2	0.56	14.3	11	5	8.94	227.0	2.79	70.8	1.74	44.2	5.09	129.3	10000	689	1	1 - 7/8
GTMAX-4P120	4	120	3	3.60 - 3.74	91.4 - 95.0	3.50	88.9	0.10	2.5	1/2	0.56	14.3	10	4 1/2	8.94	227.0	2.81	71.5	1.74	44.2	5.12	130.0	10000	689	1	1 - 7/8
GTMAX-4P160	4	160	3	3.41 - 3.57	86.6 - 90.7	3.31	84.1	0.10	2.5	1/2	0.56	14.3	10	4 1/2	8.94	227.0	2.87	72.9	1.74	44.2	5.17	131.4	10000	689	1	1 - 7/8
GTMAX-4PXXS	4	XXS	3	3.12 - 3.32	79.2 - 84.3	3.02	76.7	0.10	2.5	1/2	0.56	14.3	8 3/4	4	8.94	227.0	2.90	73.6	1.74	44.2	5.20	132.1	10000	689	1	1 - 7/8

Questions? Contact EST Group Customer Service at any of the following locations.



EST Group  
[www.cw-estgroup.com](http://www.cw-estgroup.com)

**North, Central & South America**  
EST Group Corporate Office  
2701 Township Line Road  
Hatfield, PA 19440-1770 USA  
P: +1.215.721.1100  
+1.800.355.7044  
F: +1.215.721.1101  
[est-info@curtisswright.com](mailto:est-info@curtisswright.com)

**Europe / Middle East / Africa**  
EST Group B.V.  
Hoorn 312a  
2404 HL Alphen aan den Rijn  
The Netherlands  
P: +31.172.418841  
F: +31.172.418849  
[est-emea@curtisswright.com](mailto:est-emea@curtisswright.com)

**China**  
P +86.400.636.5077  
[est-china@curtisswright.cn](mailto:est-china@curtisswright.cn)

**Singapore**  
P +65.3158.5052  
[est-asia@curtisswright.com](mailto:est-asia@curtisswright.com)

# GripTight MAX<sup>®</sup> Test Plug Technical Specifications

Sales Number	Nominal Pipe Size	Pipe Schedule	Type	Functional I.D. Range		Plug OD		Total clearance from Min. I.D.		NPT Size	Shaft / Port I.D.		Approximate Weight		Overall Length		Seal to Gripper		Gripper Length		Full Installation Depth		Maximum Test Pressure		Shaft Hex Wrench Size (in)	Hex Nut Wrench Size (in)		
				(in)		(mm)		(in)	(mm)		(in)	(mm)	(in)	(mm)	(lbs)	(kg)	(in)	(mm)	(in)	(mm)	(in)	(mm)	(in)	(mm)			(PsiG)	(BarG)
				Min	Max	Min	Max																					
GTMAX-5P5	5	5	5	5.32 - 5.44	135.1 - 138.2	5.21	132.3	0.11	2.8	1/2	0.46	11.8	28	12 3/4	8.56	217.4	3.84	97.6	2.02	51.3	5.27	134.0	8000	552	-	3/4		
GTMAX-5P10	5	10	5	5.27 - 5.39	133.9 - 136.9	5.16	131.1	0.11	2.8	1/2	0.46	11.8	27	12 1/4	8.56	217.4	3.84	97.6	2.02	51.3	5.27	134.0	8000	552	-	3/4		
GTMAX-514T			5	5.14 - 5.26	130.6 - 133.6	5.03	127.8	0.11	2.8	1/2	0.46	11.8	26	11 3/4	8.56	217.4	3.84	97.6	2.02	51.3	5.27	134.0	8000	552	-	3/4		
GTMAX-5P40	5	40/ STD	5	5.02 - 5.14	127.5 - 130.6	4.91	124.7	0.11	2.8	1/2	0.46	11.8	24	10 3/4	8.56	217.4	3.84	97.6	2.02	51.3	5.27	134.0	8000	552	-	3/4		
GTMAX-5P80	5	80/ XS	4	4.78 - 4.91	121.4 - 124.7	4.67	118.6	0.11	2.8	3/4	0.75	19.1	21	9 1/2	10.13	257.2	3.47	88.3	2.15	54.6	6.08	154.6	8000	552	1 - 1/4	2 - 1/4		
GTMAX-466T			4	4.66 - 4.82	118.4 - 122.4	4.55	115.6	0.11	2.8	3/4	0.75	19.1	20	9	10.13	257.2	3.53	89.7	2.15	54.6	6.14	155.9	8000	552	1 - 1/4	2 - 1/4		
GTMAX-5P120	5	120	4	4.53 - 4.69	115.1 - 119.1	4.42	112.3	0.11	2.8	3/4	0.75	19.1	19	8 1/2	10.13	257.2	3.53	89.7	2.15	54.6	6.14	155.9	8000	552	1 - 1/4	2 - 1/4		
GTMAX-442T			4	4.42 - 4.58	112.3 - 116.3	4.31	109.5	0.11	2.8	3/4	0.75	19.1	19	8 1/2	10.13	257.2	3.53	89.7	2.15	54.6	6.14	155.9	8000	552	1 - 1/4	2 - 1/4		
GTMAX-5P160	5	160	4	4.28 - 4.47	108.7 - 113.5	4.17	105.9	0.11	2.8	3/4	0.75	19.1	18	8 1/4	10.13	257.2	3.56	90.3	2.15	54.6	6.17	156.6	10000	689	1 - 1/4	2 - 1/4		
GTMAX-5PXXS	5	XXS	3	4.03 - 4.25	102.4 - 108.0	3.92	99.6	0.11	2.8	1/2	0.56	14.3	14	6 1/4	8.94	227.0	3.46	87.9	2.25	57.2	5.77	146.5	8000	552	1	1 - 7/8		
GTMAX-668T			5	6.68 - 6.82	169.7 - 173.2	6.56	166.6	0.12	3.0	3/4	0.46	11.8	47	21 1/4	9.56	242.8	4.23	107.4	2.35	59.7	5.66	143.8	8000	552	-	1 - 1/16		
GTMAX-653T			5	6.53 - 6.67	165.9 - 169.4	6.41	162.8	0.12	3.0	3/4	0.46	11.8	45	20 1/2	9.56	242.8	4.23	107.4	2.35	59.7	5.66	143.8	8000	552	-	1 - 1/16		
GTMAX-6P5	6	5	5	6.38 - 6.52	162.1 - 165.6	6.26	159.0	0.12	3.0	3/4	0.46	11.8	43	19 1/2	9.56	242.8	4.20	106.7	2.35	59.7	5.63	143.1	8000	552	-	1 - 1/16		
GTMAX-6P10	6	10	5	6.33 - 6.47	160.8 - 164.3	6.21	157.7	0.12	3.0	3/4	0.46	11.8	42	19	9.56	242.8	4.20	106.7	2.35	59.7	5.63	143.1	8000	552	-	1 - 1/16		
GTMAX-618T			5	6.18 - 6.32	157.0 - 160.5	6.06	153.9	0.12	3.0	1/2	0.46	11.8	40	18	9.43	239.6	4.23	107.4	2.35	59.7	5.66	143.8	8000	552	-	3/4		
GTMAX-6P40	6	40/ STD	5	6.04 - 6.17	153.4 - 156.7	5.92	150.4	0.12	3.0	1/2	0.46	11.8	37	16 3/4	9.43	239.6	4.20	106.7	2.35	59.7	5.63	143.1	8000	552	-	3/4		
GTMAX-588T			5	5.88 - 6.03	149.4 - 153.2	5.76	146.3	0.12	3.0	1/2	0.46	11.8	35	15 3/4	9.43	239.6	4.23	107.4	2.35	59.7	5.66	143.8	8000	552	-	3/4		
GTMAX-6P80	6	80/ XS	5	5.73 - 5.87	145.5 - 149.1	5.62	142.7	0.11	2.8	1/2	0.46	11.8	33	15	9.43	239.6	4.20	106.7	2.35	59.7	5.63	143.1	8000	552	-	3/4		
GTMAX-562T			5	5.62 - 5.76	142.7 - 146.3	5.51	140.0	0.11	2.8	1/2	0.46	11.8	32	14 1/2	9.43	239.6	4.20	106.7	2.35	59.7	5.63	143.1	8000	552	-	3/4		
GTMAX-6P120	6	120	5	5.47 - 5.64	138.9 - 143.3	5.36	136.1	0.11	2.8	1/2	0.46	11.8	30	13 1/2	9.43	239.6	4.25	108.1	2.35	59.7	5.69	144.5	8000	552	-	3/4		
GTMAX-534T			5	5.34 - 5.51	135.6 - 140.0	5.23	132.8	0.11	2.8	1/2	0.46	11.8	28	12 3/4	9.43	239.6	4.25	108.1	2.35	59.7	5.69	144.5	8000	552	-	3/4		
GTMAX-6P160	6	160	5	5.16 - 5.37	131.1 - 136.4	5.05	128.3	0.11	2.8	1/2	0.46	11.8	26	11 3/4	9.43	239.6	4.42	112.3	2.49	63.2	5.85	148.7	8000	552	-	3/4		
GTMAX-6PXXS	6	XXS	5	4.87 - 5.11	123.7 - 129.8	4.76	120.9	0.11	2.8	1/2	0.46	11.8	23	10 1/2	9.43	239.6	4.48	113.7	2.49	63.2	5.91	150.1	8000	552	-	3/4		
GTMAX-8P5	8	5	5	8.38 - 8.53	212.9 - 216.7	8.26	209.8	0.12	3.0	3/4	0.61	15.5	78	35 1/4	10.96	278.4	4.75	120.6	2.76	70.1	6.46	164.0	8000	552	-	1 - 7/16		
GTMAX-8P10	8	10	5	8.30 - 8.45	210.8 - 214.6	8.18	207.8	0.12	3.0	3/4	0.61	15.5	77	35	10.96	278.4	4.75	120.6	2.76	70.1	6.46	164.0	8000	552	-	1 - 7/16		
GTMAX-820T			5	8.20 - 8.35	208.3 - 212.1	8.08	205.2	0.12	3.0	3/4	0.61	15.5	75	34	10.96	278.4	4.75	120.6	2.76	70.1	6.46	164.0	8000	552	-	1 - 7/16		
GTMAX-8P20	8	20	5	8.10 - 8.25	205.7 - 209.6	7.98	202.7	0.12	3.0	3/4	0.61	15.5	73	33	10.96	278.4	4.75	120.6	2.76	70.1	6.46	164.0	8000	552	-	1 - 7/16		
GTMAX-8P30	8	30	5	8.04 - 8.19	204.2 - 208.0	7.92	201.2	0.12	3.0	3/4	0.61	15.5	72	32 1/2	10.96	278.4	4.75	120.6	2.76	70.1	6.46	164.0	8000	552	-	1 - 7/16		
GTMAX-8P40	8	40/ STD	5	7.95 - 8.10	201.9 - 205.7	7.83	198.9	0.12	3.0	3/4	0.61	15.5	70	31 3/4	10.96	278.4	4.75	120.6	2.76	70.1	6.46	164.0	8000	552	-	1 - 1/16		
GTMAX-787T			5	7.87 - 8.02	199.9 - 203.7	7.75	196.9	0.12	3.0	3/4	0.61	15.5	68	30 3/4	10.96	278.4	4.75	120.6	2.76	70.1	6.46	164.0	8000	552	-	1 - 1/16		
GTMAX-8P60	8	60	5	7.78 - 7.93	197.6 - 201.4	7.66	194.6	0.12	3.0	3/4	0.61	15.5	67	30 1/4	10.96	278.4	4.75	120.6	2.76	70.1	6.46	164.0	8000	552	-	1 - 1/16		
GTMAX-769T			5	7.69 - 7.84	195.3 - 199.1	7.57	192.3	0.12	3.0	3/4	0.61	15.5	65	29 1/2	10.96	278.4	4.75	120.6	2.76	70.1	6.46	164.0	8000	552	-	1 - 1/16		
GTMAX-8P80	8	80/ XS	5	7.60 - 7.75	193.0 - 196.9	7.48	190.0	0.12	3.0	3/4	0.61	15.5	63	28 1/2	10.96	278.4	4.75	120.6	2.76	70.1	6.46	164.0	8000	552	-	1 - 1/16		
GTMAX-8P100	8	100	5	7.41 - 7.59	188.2 - 192.8	7.29	185.2	0.12	3.0	3/4	0.61	15.5	60	27 1/4	10.96	278.4	4.86	123.4	2.76	70.1	6.57	166.8	8000	552	-	1 - 1/16		
GTMAX-730T			5	7.30 - 7.48	185.4 - 190.0	7.18	182.4	0.12	3.0	3/4	0.61	15.5	58	26 1/4	10.96	278.4	4.86	123.4	2.76	70.1	6.57	166.8	8000	552	-	1 - 1/16		
GTMAX-8P120	8	120	5	7.16 - 7.37	181.9 - 187.2	7.04	178.8	0.12	3.0	3/4	0.61	15.5	55	25	10.68	271.3	4.86	123.4	2.76	70.1	6.29	159.8	8000	552	-	1 - 1/16		
GTMAX-8P140	8	140	5	6.97 - 7.20	177.0 - 182.9	6.85	174.0	0.12	3.0	3/4	0.61	15.5	52	23 1/2	10.68	271.3	4.99	126.9	2.76	70.1	6.43	163.2	8000	552	-	1 - 1/16		
GTMAX-8P160	8	160	5	6.78 - 7.04	172.2 - 178.8	6.66	169.2	0.12	3.0	3/4	0.61	15.5	49	22 1/4	10.68	271.3	4.99	126.9	2.76	70.1	6.43	163.2	8000	552	-	1 - 1/16		
GTMAX-8PXXS	8	XXS	5	6.85 - 7.09	174.0 - 180.1	6.73	170.9	0.12	3.0	3/4	0.61	15.5	50	22 3/4	10.68	271.3	4.99	126.9	2.76	70.1	6.43	163.2	8000	552	-	1 - 1/16		

Questions? Contact EST Group Customer Service at any of the following locations.



EST Group  
[www.cw-estgroup.com](http://www.cw-estgroup.com)

**North, Central & South America**  
EST Group Corporate Office  
2701 Township Line Road  
Hatfield, PA 19440-1770 USA  
P: +1.215.721.1100  
+1.800.355.7044  
F: +1.215.721.1101  
[est-info@curtisswright.com](mailto:est-info@curtisswright.com)

**Europe / Middle East / Africa**  
EST Group B.V.  
Hoorn 312a  
2404 HL Alphen aan den Rijn  
The Netherlands  
P: +31.172.418841  
F: +31.172.418849  
[est-emea@curtisswright.com](mailto:est-emea@curtisswright.com)

**China**  
P +86.400.636.5077  
[est-china@curtisswright.cn](mailto:est-china@curtisswright.cn)

**Singapore**  
P +65.3158.5052  
[est-asia@curtisswright.com](mailto:est-asia@curtisswright.com)

# GripTight MAX<sup>®</sup> Test Plug Technical Specifications

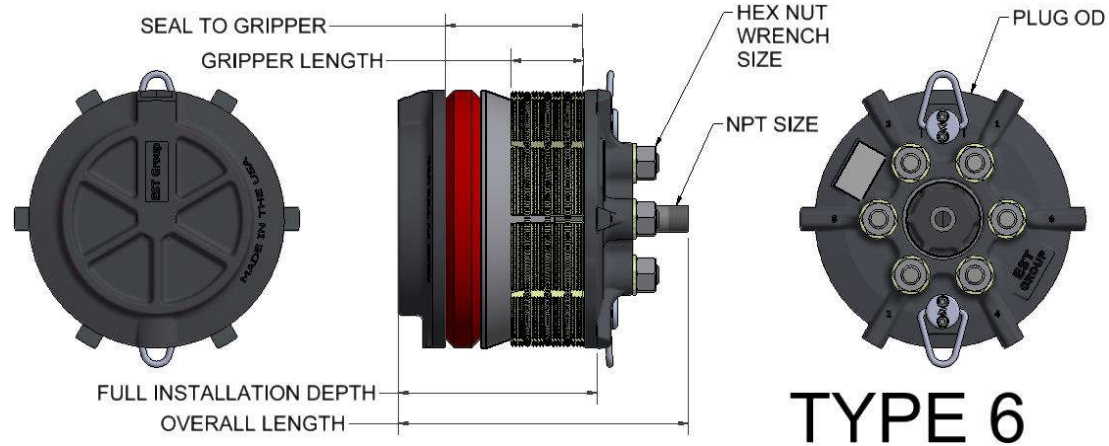

Sales Number	Nominal Pipe Size	Pipe Schedule	Type	Functional I.D. Range		Plug OD		Total clearance from Min. I.D.		NPT Size	Shaft / Port I.D.		Approximate Weight		Overall Length		Seal to Gripper		Gripper Length		Full Installation Depth		Maximum Test Pressure		Hex Nut Wrench Size (in)		
				Min	Max	(in)	(mm)	(in)	(mm)		(in)	(mm)	(in)	(mm)	(in)	(mm)	(in)	(mm)	(in)	(mm)	(in)	(mm)	(PsiG)	(BarG)			
GTMAX-10P5	10	5	6	10.42	10.88	264.7	276.4	10.32	262.1	0.10	2.5	1	0.82	20.8	128	58	12.34	313.4	5.84	148.4	2.88	73.2	8.76	222.5	3000	207	1 - 5/8
GTMAX-10P10	10	10S	6	10.34	10.80	262.6	274.3	10.24	260.1	0.10	2.5	1	0.82	20.8	127	58	12.34	313.4	5.84	148.4	2.88	73.2	8.77	222.8	3000	207	1 - 5/8
GTMAX-10P20	10	20	6	10.17	10.63	258.3	270.0	10.07	255.8	0.10	2.5	1	0.82	20.8	123	56	12.34	313.4	5.84	148.4	2.88	73.2	8.79	223.3	3000	207	1 - 5/8
GTMAX-10P30	10	30	6	10.06	10.52	255.5	267.2	9.96	253.0	0.10	2.5	1	0.82	20.8	120	54	12.34	313.4	5.84	148.4	2.88	73.2	8.81	223.8	3000	207	1 - 5/8
GTMAX-10P40	10	40 / STD	6	9.94	10.40	252.5	264.2	9.84	249.9	0.10	2.5	1	0.82	20.8	118	54	12.34	313.4	5.84	148.4	2.88	73.2	8.82	224.1	3000	207	1 - 5/8
GTMAX-10PXS	10	XS / 60	6	9.67	10.13	245.6	257.3	9.57	243.1	0.10	2.5	1	0.82	20.8	112	51	12.34	313.4	5.84	148.4	2.88	73.2	8.86	225.1	5000	345	1 - 5/8
GTMAX-10P80	10	80	6	9.48	9.94	240.8	252.5	9.38	238.3	0.10	2.5	1	0.82	20.8	108	49	12.34	313.4	5.84	148.4	2.88	73.2	8.89	225.8	5000	345	1 - 5/8
GTMAX-10P100	10	100	6	9.23	9.69	234.4	246.1	9.13	231.9	0.10	2.5	1	0.82	20.8	103	47	12.34	313.4	5.84	148.4	2.88	73.2	8.89	225.8	5000	345	1 - 5/8
GTMAX-10P120	10	120	5	9.01	9.47	228.9	240.5	8.91	226.3	0.10	2.5	3/4	0.61	15.5	92	42	10.96	278.4	5.29	134.3	3.00	76.2	7.63	193.8	6000	414	1 - 7/16
GTMAX-10P140	10	140	5	8.70	9.16	221.0	232.7	8.60	218.4	0.10	2.5	3/4	0.61	15.5	86	39	10.96	278.4	5.29	134.3	3.00	76.2	7.63	193.8	6000	414	1 - 7/16
GTMAX-10P160	10	160	5	8.45	8.91	214.6	226.3	8.35	212.1	0.10	2.5	3/4	0.61	15.5	80	36	10.96	278.4	5.29	134.3	3.00	76.2	7.63	193.8	6000	414	1 - 7/16
GTMAX-12P10	12	10S / 5	6	12.30	12.76	312.4	324.1	12.20	309.9	0.10	2.5	1	0.82	20.8	179	81	12.41	315.2	6.33	160.8	3.37	85.6	9.44	239.8	3000	207	1 - 5/8
GTMAX-12P20	12	20	6	12.17	12.63	309.1	320.8	12.07	306.6	0.10	2.5	1	0.82	20.8	175	79	12.41	315.2	6.33	160.8	3.37	85.6	9.46	240.3	3000	207	1 - 5/8
GTMAX-12P30	12	30	6	12.01	12.47	305.1	316.7	11.91	302.5	0.10	2.5	1	0.82	20.8	171	78	12.41	315.2	6.33	160.8	3.37	85.6	9.47	240.6	3000	207	1 - 5/8
GTMAX-12P40	12	40 / STD	6	11.92	12.38	302.8	314.5	11.82	300.2	0.10	2.5	1	0.82	20.8	168	76	12.41	315.2	6.33	160.8	3.37	85.6	9.48	240.8	3000	207	1 - 5/8
GTMAX-12PXS	12	XS	6	11.67	12.13	296.4	308.1	11.57	293.9	0.10	2.5	1	0.82	20.8	161	73	12.34	313.4	6.33	160.8	3.37	85.6	9.42	239.3	5000	345	1 - 5/8
GTMAX-12P60	12	60	6	11.55	12.01	293.4	305.1	11.45	290.8	0.10	2.5	1	0.82	20.8	157	71	12.34	313.4	6.33	160.8	3.37	85.6	9.08	230.7	5000	345	1 - 5/8
GTMAX-12P80	12	80	6	11.29	11.75	286.8	298.5	11.19	284.2	0.10	2.5	1	0.82	20.8	150	68	12.34	313.4	6.33	160.8	3.37	85.6	9.12	231.7	5000	345	1 - 5/8
GTMAX-12P100	12	100	6	10.98	11.44	278.9	290.6	10.88	276.4	0.10	2.5	1	0.82	20.8	142	64	12.34	313.4	5.84	148.4	2.88	73.2	8.67	220.3	5000	345	1 - 5/8
GTMAX-12P120	12	120 / XXS	6	10.67	11.13	271.0	282.7	10.57	268.5	0.10	2.5	1	0.82	20.8	134	61	12.34	313.4	5.84	148.4	2.88	73.2	8.72	221.5	5000	345	1 - 5/8
GTMAX-12P140	12	140	6	10.42	10.88	264.7	276.4	10.32	262.1	0.10	2.5	1	0.82	20.8	128	58	12.34	313.4	5.84	148.4	2.88	73.2	8.76	222.5	6000	414	1 - 5/8
GTMAX-12P160	12	160	6	10.06	10.52	255.5	267.2	9.96	253.0	0.10	2.5	1	0.82	20.8	120	54	12.34	313.4	5.84	148.4	2.88	73.2	8.81	223.8	6000	414	1 - 5/8

Questions? Contact EST Group Customer Service at any of the following locations.



EST Group  
[www.cw-estgroup.com](http://www.cw-estgroup.com)

**North, Central & South America**  
EST Group Corporate Office  
2701 Township Line Road  
Hatfield, PA 19440-1770 USA  
P: +1.215.721.1100  
+1.800.355.7044  
F: +1.215.721.1101  
[est-info@curtisswright.com](mailto:est-info@curtisswright.com)

**Europe / Middle East / Africa**  
EST Group B.V.  
Hoorn 312a  
2404 HL Alphen aan den Rijn  
The Netherlands  
P: +31.172.418841  
F: +31.172.418849  
[est-emea@curtisswright.com](mailto:est-emea@curtisswright.com)

**China**  
P +86.400.636.5077  
[est-china@curtisswright.cn](mailto:est-china@curtisswright.cn)

**Singapore**  
P +65.3158.5052  
[est-asia@curtisswright.com](mailto:est-asia@curtisswright.com)

# GripTight MAX<sup>®</sup> Test Plug Technical Specifications

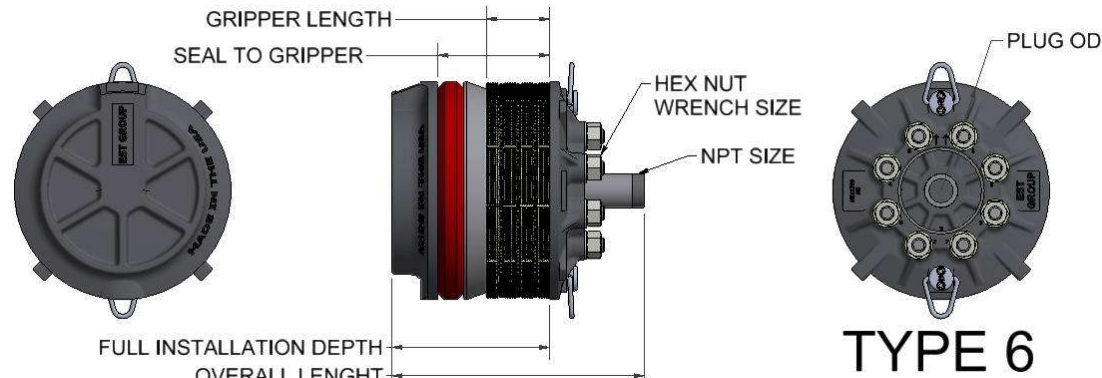

Sales Number	Nominal Pipe Size	Pipe Schedule	Type	Functional I.D. Range		Plug OD		Total clearance from Min. I.D.		NPT Size	Shaft / Port I.D.		Approximate Weight		Overall Length		Seal to Gripper		Gripper Length		Full Installation Depth		Maximum Test Pressure		Hex Nut Wrench Size (in)
				(in)		(mm)		(in)	(mm)		(in)	(mm)	(in)	(mm)	(in)	(mm)	(in)	(mm)	(in)	(mm)	(in)	(mm)	(PsiG)	(BarG)	
				Min	Max	Min	Max																		
GTMAX-14P5	14	5	6	13.60 - 14.06	345.4 - 357.1	13.50	342.9	0.10	2.5	1	0.82	20.8	223	101	12.41	315.2	6.86	174.2	3.73	94.7	9.83	249.6	3000	207	1 - 5/8
GTMAX-14P10S	14	10S	6	13.54 - 14.00	343.9 - 355.6	13.44	341.4	0.10	2.5	1	0.82	20.8	221	100	12.41	315.2	6.86	174.2	3.73	94.7	9.84	249.8	3000	207	1 - 5/8
GTMAX-14P10	14	10	6	13.41 - 13.87	340.6 - 352.3	13.31	338.1	0.10	2.5	1	0.82	20.8	216	98	12.41	315.2	6.86	174.2	3.73	94.7	9.85	250.1	3000	207	1 - 5/8
GTMAX-14P20	14	20	6	13.30 - 13.76	337.8 - 349.5	13.20	335.3	0.10	2.5	1	0.82	20.8	212	96	12.41	315.2	6.86	174.2	3.73	94.7	9.86	250.4	3000	207	1 - 5/8
GTMAX-14PSTD	14	STD / 30	6	13.17 - 13.63	334.5 - 346.2	13.07	332.0	0.10	2.5	1	0.82	20.8	208	94	12.41	315.2	6.86	174.2	3.73	94.7	9.88	250.9	3000	207	1 - 5/8
GTMAX-14P40	14	40	6	13.04 - 13.50	331.2 - 342.9	12.94	328.7	0.10	2.5	1	0.82	20.8	203	92	12.41	315.2	6.86	174.2	3.73	94.7	9.89	251.1	5000	345	1 - 5/8
GTMAX-14PXS	14	XS	6	12.92 - 13.38	328.2 - 339.9	12.82	325.6	0.10	2.5	1	0.82	20.8	199	90	12.41	315.2	6.86	174.2	3.73	94.7	9.91	251.6	5000	345	1 - 5/8
GTMAX-14P60	14	60	6	12.73 - 13.19	323.3 - 335.0	12.63	320.8	0.10	2.5	1	0.82	20.8	193	88	12.41	315.2	6.86	174.2	3.73	94.7	9.93	252.1	5000	345	1 - 5/8
GTMAX-14P80	14	80	6	12.42 - 12.88	315.5 - 327.2	12.32	312.9	0.10	2.5	1	0.82	20.8	183	83	12.41	315.2	6.86	174.2	3.73	94.7	9.96	252.9	5000	345	1 - 5/8
GTMAX-14P100	14	100	6	12.04 - 12.50	305.8 - 317.5	11.94	303.3	0.10	2.5	1	0.82	20.8	172	78	12.41	315.2	6.33	160.8	3.37	85.6	9.43	239.6	5000	345	1 - 5/8
GTMAX-14P120	14	120	6	11.73 - 12.19	297.9 - 309.6	11.63	295.4	0.10	2.5	1	0.82	20.8	163	74	12.34	313.4	6.33	160.8	3.37	85.6	9.12	231.7	5000	345	1 - 5/8
GTMAX-14P140	14	140	6	11.42 - 11.91	290.1 - 302.5	11.32	287.5	0.10	2.5	1	0.82	20.8	154	70	12.34	313.4	6.33	160.8	3.37	85.6	9.17	233.0	5000	345	1 - 5/8
GTMAX-14P160	14	160	6	11.10 - 11.56	281.9 - 293.6	11.00	279.4	0.10	2.5	1	0.82	20.8	145	66	12.34	313.4	6.33	160.8	3.37	85.6	9.22	234.2	6000	414	1 - 5/8
GTMAX-16P10S	16	10S / 5	6	15.54 - 16.00	394.7 - 406.4	15.44	392.2	0.10	2.5	2	1.69	42.9	324	147	17.19	436.6	7.53	191.2	4.40	111.8	11.34	287.9	3000	207	1 - 5/8
GTMAX-16P10	16	10	6	15.42 - 15.88	391.7 - 403.4	15.32	389.1	0.10	2.5	2	1.69	42.9	315	143	17.19	436.6	7.53	191.2	4.40	111.8	11.35	288.2	3000	207	1 - 5/8
GTMAX-16P20	16	20	6	15.30 - 15.76	388.6 - 400.3	15.20	386.1	0.10	2.5	2	1.69	42.9	307	139	17.19	436.6	7.53	191.2	4.40	111.8	11.37	288.7	3000	207	1 - 5/8
GTMAX-16PSTD	16	STD / 30	6	15.17 - 15.69	385.3 - 398.5	15.07	382.8	0.10	2.5	2	1.69	42.9	298	135	17.19	436.6	7.53	191.2	4.40	111.8	11.39	289.2	3000	207	1 - 5/8
GTMAX-16P40	16	40 / XS	6	14.92 - 15.38	379.0 - 390.7	14.82	376.4	0.10	2.5	2	1.69	42.9	280	127	17.19	436.6	7.53	191.2	4.40	111.8	11.42	290.0	5000	345	1 - 5/8
GTMAX-16P60	16	60	6	14.61 - 15.07	371.1 - 382.8	14.51	368.6	0.10	2.5	2	1.69	42.9	258	117	17.19	436.6	7.53	191.2	4.40	111.8	11.46	291.0	5000	345	1 - 5/8
GTMAX-16P80	16	80	6	14.23 - 14.69	361.4 - 373.1	14.13	358.9	0.10	2.5	1	0.82	20.8	246	112	14.41	366.0	7.53	191.2	4.40	111.8	10.43	264.8	5000	345	1 - 5/8
GTMAX-16P100	16	100	6	13.86 - 14.32	352.0 - 363.7	13.76	349.5	0.10	2.5	1	0.82	20.8	232	105	14.41	366.0	7.53	191.2	4.40	111.8	10.47	265.8	5000	345	1 - 5/8
GTMAX-16P120	16	120	6	13.48 - 13.96	342.4 - 354.6	13.38	339.9	0.10	2.5	1	0.82	20.8	218	99	12.41	315.2	6.86	174.2	3.73	94.7	9.84	249.8	5000	345	1 - 5/8
GTMAX-16P140	16	140	6	13.04 - 13.50	331.2 - 342.9	12.94	328.7	0.10	2.5	1	0.82	20.8	203	92	12.41	315.2	6.86	174.2	3.73	94.7	9.89	251.1	5000	345	1 - 5/8
GTMAX-16P160	16	160	6	12.73 - 13.19	323.3 - 335.0	12.63	320.8	0.10	2.5	1	0.82	20.8	193	88	12.41	315.2	6.86	174.2	3.73	94.7	9.93	252.1	5000	345	1 - 5/8

Questions? Contact EST Group Customer Service at any of the following locations.



EST Group  
[www.cw-estgroup.com](http://www.cw-estgroup.com)

**North, Central & South America**  
EST Group Corporate Office  
2701 Township Line Road  
Hatfield, PA 19440-1770 USA  
P: +1.215.721.1100  
+1.800.355.7044  
F: +1.215.721.1101  
[est-info@curtisswright.com](mailto:est-info@curtisswright.com)

**Europe / Middle East / Africa**  
EST Group B.V.  
Hoorn 312a  
2404 HL Alphen aan den Rijn  
The Netherlands  
P: +31.172.418841  
F: +31.172.418849  
[est-emea@curtisswright.com](mailto:est-emea@curtisswright.com)

**China**  
P +86.400.636.5077  
[est-china@curtisswright.cn](mailto:est-china@curtisswright.cn)

**Singapore**  
P +65.3158.5052  
[est-asia@curtisswright.com](mailto:est-asia@curtisswright.com)



# GripTight MAX<sup>®</sup> Test Plug Technical Specifications

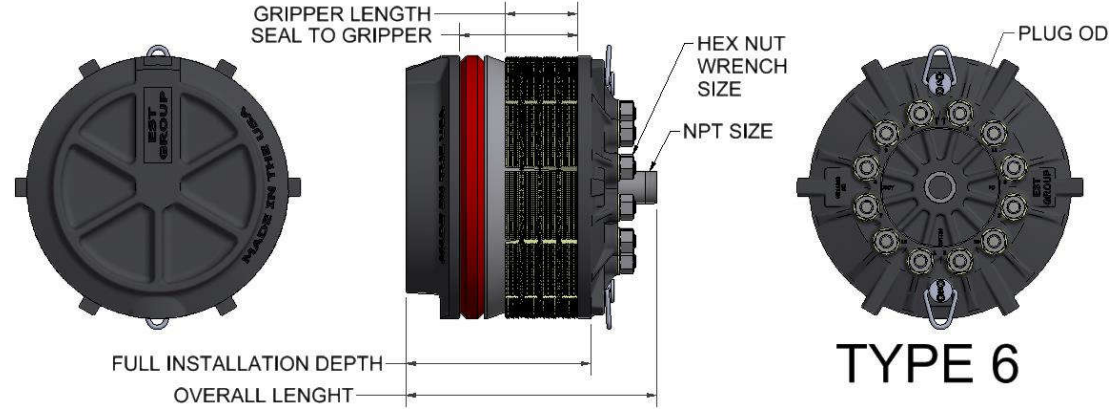

Sales Number	Nominal Pipe Size	Pipe Schedule	Type	Functional I.D. Range		Plug OD		Total clearance from Min. I.D.		NPT Size	Shaft / Port I.D.		Approximate Weight		Overall Length		Seal to Gripper		Gripper Length		Full Installation Depth		Maximum Test Pressure		Hex Nut Wrench Size (in)		
				Min	Max	(in)	(mm)	(in)	(mm)		(in)	(mm)	(in)	(mm)	(in)	(mm)	(in)	(mm)	(in)	(mm)	(in)	(mm)	(PsiG)	(BarG)			
				(in)		(mm)		(in)			(mm)		(in)		(mm)		(in)		(mm)		(in)		(mm)			(in)	
GTMAX-18P10S	18	10S / 5	6	17.55	18.01	445.8	457.5	17.45	443.2	0.10	2.5	2	1.69	42.9	453	205	17.94	455.7	7.92	201.2	4.74	120.4	12.56	319.1	3000	206.8	1 - 5/8
GTMAX-18P10	18	10	6	17.42	17.88	442.5	454.2	17.32	439.9	0.10	2.5	2	1.69	42.9	445	202	17.94	455.7	7.92	201.2	4.74	120.4	12.57	319.3	3000	206.8	1 - 5/8
GTMAX-18P20	18	20	6	17.30	17.76	439.4	451.1	17.20	436.9	0.10	2.5	2	1.69	42.9	438	199	17.94	455.7	7.92	201.2	4.74	120.4	12.59	319.8	3000	206.8	1 - 5/8
GTMAX-18PSTD	18	STD	6	17.17	17.63	436.1	447.8	17.07	433.6	0.10	2.5	2	1.69	42.9	430	195	17.94	455.7	7.92	201.2	4.74	120.4	12.60	320.1	3000	206.8	1 - 5/8
GTMAX-18P30	18	30	6	17.04	17.50	432.8	444.5	16.94	430.3	0.10	2.5	2	1.69	42.9	422	191	17.94	455.7	7.92	201.2	4.74	120.4	12.62	320.6	5000	344.7	1 - 5/8
GTMAX-18PX5	18	XS	6	16.92	17.38	429.8	441.5	16.82	427.2	0.10	2.5	2	1.69	42.9	414	188	17.94	455.7	7.92	201.2	4.74	120.4	12.63	320.8	5000	344.7	1 - 5/8
GTMAX-18P40	18	40	6	16.80	17.26	426.7	438.4	16.70	424.2	0.10	2.5	2	1.69	42.9	407	185	17.94	455.7	7.92	201.2	4.74	120.4	12.65	321.3	5000	344.7	1 - 5/8
GTMAX-18P60	18	60	6	16.42	16.88	417.1	428.8	16.32	414.5	0.10	2.5	2	1.69	42.9	383	174	17.94	455.7	7.92	201.2	4.74	120.4	12.70	322.6	5000	344.7	1 - 5/8
GTMAX-18P80	18	80	6	16.04	16.50	407.4	419.1	15.94	404.9	0.10	2.5	2	1.69	42.9	358	162	17.19	436.6	7.92	201.2	4.74	120.4	11.66	296.2	5000	344.7	1 - 5/8
GTMAX-18P100	18	100	6	15.61	16.07	396.5	408.2	15.51	394.0	0.10	2.5	2	1.69	42.9	329	149	17.19	436.6	7.53	191.2	4.40	111.8	11.33	287.7	5000	344.7	1 - 5/8
GTMAX-18P120	18	120	6	15.17	15.69	385.3	398.5	15.07	382.8	0.10	2.5	2	1.69	42.9	298	135	17.19	436.6	7.53	191.2	4.40	111.8	11.39	289.2	5000	344.7	1 - 5/8
GTMAX-18P140	18	140	6	14.79	15.25	375.7	387.4	14.69	373.1	0.10	2.5	2	1.69	42.9	271	123	17.19	436.6	7.53	191.2	4.40	111.8	11.44	290.5	5000	344.7	1 - 5/8
GTMAX-18P160	18	160	6	14.35	14.81	364.5	376.2	14.25	362.0	0.10	2.5	2	1.69	42.9	239	108	17.19	436.6	7.53	191.2	4.40	111.8	11.50	292.0	5000	344.7	1 - 5/8
GTMAX-20P10	20	10 / 10S / 5	6	19.48	19.94	494.8	506.5	19.38	492.3	0.10	2.5	2	1.69	42.9	560	254	17.94	455.7	8.56	217.4	5.24	133.1	12.50	317.5	3000	206.8	1 - 5/8
GTMAX-20PSTD	20	STD / 20	6	19.17	19.72	486.9	500.9	19.07	484.4	0.10	2.5	2	1.69	42.9	544	247	17.94	455.7	8.42	213.9	5.24	133.1	13.34	338.9	3000	206.8	1 - 5/8
GTMAX-20P30	20	30 / XS	6	18.92	19.38	480.6	492.3	18.82	478.0	0.10	2.5	2	1.69	42.9	531	241	17.94	455.7	8.42	213.9	5.24	133.1	13.38	339.9	5000	344.7	1 - 5/8
GTMAX-20P40	20	40	6	18.73	19.19	475.7	487.4	18.63	473.2	0.10	2.5	2	1.69	42.9	520	236	17.94	455.7	8.42	213.9	5.24	133.1	13.41	340.6	5000	344.7	1 - 5/8
GTMAX-20P60	20	60	6	18.30	18.76	464.8	476.5	18.20	462.3	0.10	2.5	2	1.69	42.9	497	225	17.94	455.7	8.42	213.9	5.24	133.1	12.97	329.5	5000	344.7	1 - 5/8
GTMAX-20P80	20	80	6	17.86	18.32	453.6	465.3	17.76	451.1	0.10	2.5	2	1.69	42.9	471	214	17.94	455.7	8.42	213.9	5.24	133.1	13.02	330.7	5000	344.7	1 - 5/8
GTMAX-20P100	20	100	6	17.36	17.88	440.9	454.2	17.26	438.4	0.10	2.5	2	1.69	42.9	442	200	17.94	455.7	7.92	201.2	4.74	120.4	12.58	319.6	5000	344.7	1 - 5/8
GTMAX-20P120	20	120	6	16.92	17.38	429.8	441.5	16.82	427.2	0.10	2.5	2	1.69	42.9	414	188	17.94	455.7	7.92	201.2	4.74	120.4	12.63	320.8	5000	344.7	1 - 5/8
GTMAX-20P140	20	140	6	16.42	16.88	417.1	428.8	16.32	414.5	0.10	2.5	2	1.69	42.9	383	174	17.94	455.7	7.92	201.2	4.74	120.4	12.70	322.6	5000	344.7	1 - 5/8
GTMAX-20P160	20	160	6	15.98	16.43	405.9	417.3	15.87	403.1	0.11	2.8	2	1.69	42.9	353	160	17.19	436.6	7.92	201.2	4.74	120.4	11.67	296.5	5000	344.7	1 - 5/8

Questions? Contact EST Group Customer Service at any of the following locations.



EST Group  
[www.cw-estgroup.com](http://www.cw-estgroup.com)

**North, Central & South America**  
EST Group Corporate Office  
2701 Township Line Road  
Hatfield, PA 19440-1770 USA  
P: +1.215.721.1100  
+1.800.355.7044  
F: +1.215.721.1101  
[est-info@curtisswright.com](mailto:est-info@curtisswright.com)

**Europe / Middle East / Africa**  
EST Group B.V.  
Hoorn 312a  
2404 HL Alphen aan den Rijn  
The Netherlands  
P: +31.172.418841  
F: +31.172.418849  
[est-emea@curtisswright.com](mailto:est-emea@curtisswright.com)

**China**  
P +86.400.636.5077  
[est-china@curtisswright.cn](mailto:est-china@curtisswright.cn)

**Singapore**  
P +65.3158.5052  
[est-asia@curtisswright.com](mailto:est-asia@curtisswright.com)

# GripTight MAX<sup>®</sup> Test Plug Technical Specifications

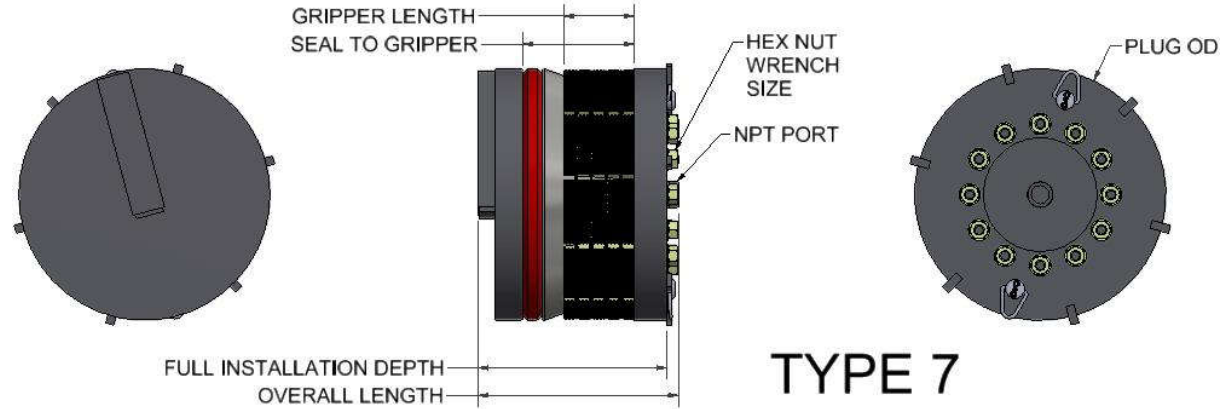

Sales Number	Nominal Pipe Size	Pipe Schedule	Type	Functional I.D. Range		Plug OD		Total clearance from Min. I.D.		NPT Size	Shaft / Port I.D.		Approximate Weight		Overall Length		Seal to Gripper		Gripper Length		Full Installation Depth		Maximum Test Pressure		Hex Nut Wrench Size		
				(in)		(mm)		(in)	(mm)		(in)	(mm)	(in)	(mm)	(lbs)	(kg)	(in)	(mm)	(in)	(mm)	(in)	(mm)	(in)	(mm)		(PsiG)	(BarG)
				Min	Max	Min	Max	(in)	(mm)		(in)	(mm)	(in)	(mm)	(in)	(kg)	(in)	(mm)	(in)	(mm)	(in)	(mm)	(in)	(mm)		(PsiG)	(BarG)
GTMAX-22P10	22	10 / 10S / 5	7	21.47	21.80	545.3	553.7	21.25	539.8	0.22	5.6	2	1.69	42.9	850	385	17.75	450.9	9.25	234.9	5.93	150.6	16.60	421.6	3000	207	1 - 5/8
GTMAX-22PSTD	22	20 / STD	7	21.22	21.47	539.0	545.3	21.00	533.4	0.22	5.6	2	1.69	42.9	850	385	17.75	450.9	9.25	234.9	5.93	150.6	16.60	421.6	3000	207	1 - 5/8
GTMAX-22PXS	22	XS	7	20.97	21.25	532.6	539.8	20.75	527.1	0.22	5.6	2	1.69	42.9	850	385	18.75	476.3	9.25	234.9	5.93	150.6	17.35	440.7	5000	345	1 - 5/8
GTMAX-22P60	22	60	6	20.13	20.59	511.3	523.0	20.03	508.8	0.10	2.5	2	1.69	42.9	592	268	17.94	455.7	9.25	234.9	5.93	150.6	14.01	355.8	5000	345	1 - 5/8
GTMAX-22P80	22	80	6	19.63	20.16	498.6	512.1	19.53	496.1	0.10	2.5	2	1.69	42.9	568	257	17.94	455.7	9.25	234.9	5.93	150.6	14.09	357.9	5000	345	1 - 5/8
GTMAX-22P100	22	100	6	19.17	19.72	486.9	500.9	19.07	484.4	0.10	2.5	2	1.69	42.9	544	247	17.94	455.7	8.42	213.9	5.24	133.1	13.34	338.9	5000	345	1 - 5/8
GTMAX-22P120	22	120	6	18.68	19.14	474.5	486.2	18.58	471.9	0.10	2.5	2	1.69	42.9	518	235	17.94	455.7	8.42	213.9	5.24	133.1	13.42	340.9	5000	345	1 - 5/8
GTMAX-22P140	22	140	6	18.16	18.62	461.3	472.9	18.06	458.7	0.10	2.5	2	1.69	42.9	489	222	17.94	455.7	8.42	213.9	5.24	133.1	12.98	329.7	5000	345	1 - 5/8
GTMAX-22P160	22	160	6	17.65	18.11	448.3	460.0	17.55	445.8	0.10	2.5	2	1.69	42.9	489	222	17.94	455.7	8.42	213.9	5.24	133.1	13.05	331.5	5000	345	1 - 5/8
GTMAX-24P10	24	10 / 10S / 5	7	23.47	23.74	596.1	603.0	23.31	592.1	0.16	4.1	2	1.69	42.9	1100	499	17.75	450.9	9.89	251.1	6.43	163.3	17.99	456.8	3000	207	1 - 5/8
GTMAX-24PSTD	24	20 / STD	7	23.22	23.47	589.8	596.1	23.00	584.2	0.22	5.6	2	1.69	42.9	1100	499	17.75	450.9	9.89	251.1	6.43	163.3	17.99	456.8	3000	207	1 - 5/8
GTMAX-24PXS	24	XS	7	22.97	23.25	583.4	590.6	22.75	577.9	0.22	5.6	2	1.69	42.9	1100	499	18.75	476.3	9.89	251.1	6.43	163.3	18.74	475.9	5000	345	1 - 5/8
GTMAX-24P30	24	30	7	22.84	23.14	580.1	587.8	22.63	574.8	0.21	5.3	2	1.69	42.9	1100	499	18.75	476.3	9.89	251.1	6.43	163.3	18.74	475.9	5000	345	1 - 5/8
GTMAX-24P40	24	40	7	22.59	22.92	573.8	582.2	22.37	568.2	0.22	5.6	2	1.69	42.9	1100	499	18.75	476.3	9.89	251.1	6.43	163.3	18.74	475.9	5000	345	1 - 5/8
GTMAX-24P60	24	60	7	22.03	22.43	559.6	569.7	21.81	554.0	0.22	5.6	2	1.69	42.9	1100	499	18.75	476.3	9.89	251.1	6.43	163.3	18.74	475.9	5000	345	1 - 5/8
GTMAX-24P80	24	80	7	21.53	21.99	546.9	558.5	21.31	541.3	0.22	5.6	2	1.69	42.9	1100	499	18.75	476.3	9.25	234.9	5.93	150.6	17.60	447.0	5000	345	1 - 5/8
GTMAX-24P100	24	100	6	20.82	21.45	528.8	544.8	20.72	526.3	0.10	2.5	2	1.69	42.9	624	283	17.94	455.7	9.25	234.9	5.93	150.6	13.90	353.0	5000	345	1 - 5/8
GTMAX-24P120	24	120	6	20.26	20.95	514.6	532.1	20.16	512.1	0.10	2.5	2	1.69	42.9	598	271	17.94	455.7	9.25	234.9	5.93	150.6	13.99	355.3	5000	345	1 - 5/8
GTMAX-24P140	24	140	6	19.76	20.22	501.9	513.6	19.66	499.4	0.10	2.5	2	1.69	42.9	574	260	17.94	455.7	9.25	234.9	5.93	150.6	14.07	357.3	5000	345	1 - 5/8
GTMAX-24P160	24	160	6	19.23	19.69	488.4	500.1	19.13	485.9	0.10	2.5	2	1.69	42.9	565	256	17.94	455.7	8.42	213.9	5.24	133.1	13.33	338.6	5000	345	1 - 5/8

Questions? Contact EST Group Customer Service at any of the following locations.



EST Group  
[www.cw-estgroup.com](http://www.cw-estgroup.com)

**North, Central & South America**  
EST Group Corporate Office  
2701 Township Line Road  
Hatfield, PA 19440-1770 USA  
P: +1.215.721.1100  
+1.800.355.7044  
F: +1.215.721.1101  
[est-info@curtisswright.com](mailto:est-info@curtisswright.com)

**Europe / Middle East / Africa**  
EST Group B.V.  
Hoorn 312a  
2404 HL Alphen aan den Rijn  
The Netherlands  
P: +31.172.418841  
F: +31.172.418849  
[est-emea@curtisswright.com](mailto:est-emea@curtisswright.com)

**China**  
P +86.400.636.5077  
[est-china@curtisswright.cn](mailto:est-china@curtisswright.cn)

**Singapore**  
P +65.3158.5052  
[est-asia@curtisswright.com](mailto:est-asia@curtisswright.com)

# GripTight MAX<sup>®</sup> Test Plug Technical Specifications

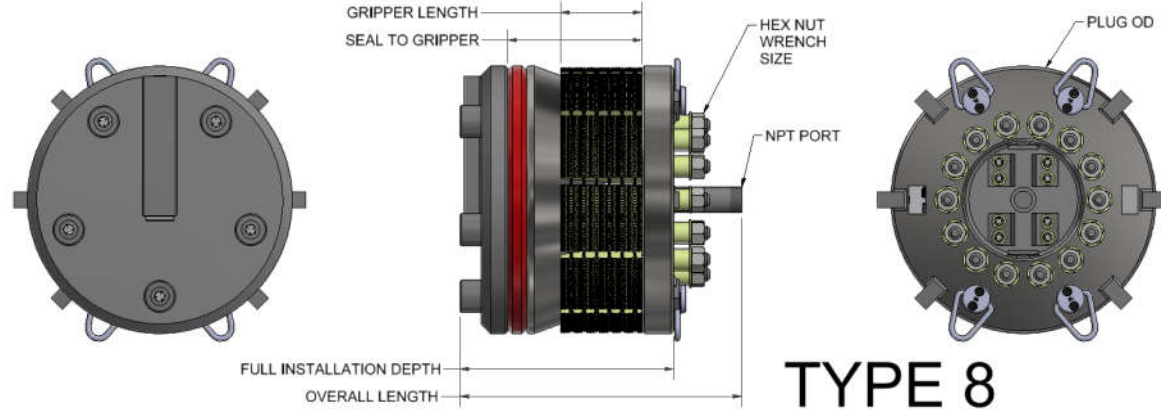

Sales Number	Nominal Pipe Size	Pipe Schedule	Type	Functional I.D. Range		Plug OD		Total clearance from Min. I.D.	NPT Size	Shaft / Port I.D.		Approximate Weight		Overall Length		Seal to Gripper		Gripper Length		Full Installation Depth		Maximum Test Pressure (PsiG) (BarG)	Hex Nut Wrench Size (in)		
				Min - Max (in)	Min - Max (mm)	(in)	(mm)			(in)	(mm)	(lbs)	(kg)	(in)	(mm)	(in)	(mm)	(in)	(mm)	(in)	(mm)				
GTMAX-26PSTD	26	STD	8	25.22 - 25.82	640.6 - 655.8	24.92	633.0	0.30	7.6	2	1.69	42.9	1555	705	25.50	647.7	12.22	310.4	7.66	194.6	19.72	500.9	1200	83	2
GTMAX-26PXS	26	XS	8	24.72 - 25.32	627.9 - 643.1	24.42	620.3	0.30	7.6	2	1.69	42.9	1535	696	25.50	647.7	12.22	310.4	7.66	194.6	19.72	500.9	1200	83	2
GTMAX-28PSTD	28	STD	8	27.22 - 27.82	691.4 - 706.6	26.92	683.8	0.30	7.6	2	1.69	42.9	1740	789	26.50	673.1	12.22	310.4	7.66	194.6	19.72	500.9	1200	83	2
GTMAX-28PXS	28	XS	8	26.72 - 27.32	678.7 - 693.9	26.42	671.1	0.30	7.6	2	1.69	42.9	1720	779	26.50	673.1	12.22	310.4	7.66	194.6	19.72	500.9	1200	83	2
GTMAX-30PSTD	30	STD	8	29.22 - 29.82	742.2 - 757.4	28.92	734.6	0.30	7.6	2	1.69	42.9	1945	881	26.50	673.1	12.22	310.4	7.66	194.6	19.72	500.9	1000	69	2
GTMAX-30PXS	30	XS	8	28.72 - 29.32	729.5 - 744.7	28.42	721.9	0.30	7.6	2	1.69	42.9	1925	872	26.50	673.1	12.22	310.4	7.66	194.6	19.72	500.9	1000	69	2
GTMAX-32PSTD	32	STD	8	31.22 - 31.82	793.0 - 808.2	30.92	785.4	0.30	7.6	2	1.69	42.9	2425	1099	27.50	698.5	14.75	374.7	9.69	246.1	22.25	565.2	900	62	2
GTMAX-32PXS	32	XS	8	30.72 - 31.32	780.3 - 795.5	30.42	772.7	0.30	7.6	2	1.69	42.9	2405	1090	27.50	698.5	14.75	374.7	9.69	246.1	22.25	565.2	900	62	2
GTMAX-34P10	34	10	8	33.28 - 33.88	845.3 - 860.6	32.98	837.7	0.30	7.6	2	1.69	42.9	2720	1233	27.50	698.5	14.75	374.7	9.69	246.1	22.25	565.2	900	62	2
GTMAX-34PXS/STD	34	XS/STD	8	32.97 - 33.57	837.4 - 852.7	32.67	829.8	0.30	7.6	2	1.69	42.9	2700	1223	27.50	698.5	14.75	374.7	9.69	246.1	22.25	565.2	900	62	2
GTMAX-36PSTD	36	STD	8	35.22 - 35.82	894.6 - 909.8	34.92	887.0	0.30	7.6	2	1.69	42.9	3145	1425	28.00	711.2	14.75	374.7	9.69	246.1	22.75	577.9	800	55	2
GTMAX-36PXS	36	XS	8	34.72 - 35.32	881.9 - 897.1	34.42	874.3	0.30	7.6	2	1.69	42.9	3120	1414	28.00	711.2	14.75	374.7	9.69	246.1	22.75	577.9	800	55	2
GTMAX-38PSTD	38	STD	8	37.22 - 37.82	945.4 - 960.6	36.92	937.8	0.30	7.6	2	1.69	42.9	3625	1643	30.00	762.0	16.65	422.9	11.59	294.4	24.65	626.1	750	52	2
GTMAX-38PXS	38	XS	8	36.72 - 37.32	932.7 - 947.9	36.42	925.1	0.30	7.6	2	1.69	42.9	3600	1631	30.00	762.0	16.65	422.9	11.59	294.4	24.65	626.1	750	52	2
GTMAX-40PSTD	40	STD	8	39.22 - 39.82	996.2 - 1011.4	38.92	988.6	0.30	7.6	2	1.69	42.9	3865	1751	30.00	762.0	16.65	422.9	11.59	294.4	24.65	626.1	750	52	2
GTMAX-40PXS	40	XS	8	38.72 - 39.32	983.5 - 998.7	38.42	975.9	0.30	7.6	2	1.69	42.9	3840	1740	30.00	762.0	16.65	422.9	11.59	294.4	24.65	626.1	750	52	2
GTMAX-42PSTD	42	STD	8	41.22 - 41.82	1047.0 - 1062.2	40.92	1039.4	0.30	7.6	2	1.69	42.9	4355	1973	30.00	762.0	16.65	422.9	11.59	294.4	24.65	626.1	700	48	2
GTMAX-42PXS	42	XS	8	40.72 - 41.32	1034.3 - 1049.5	40.42	1026.7	0.30	7.6	2	1.69	42.9	4330	1962	30.00	762.0	16.65	422.9	11.59	294.4	24.65	626.1	700	48	2
GTMAX-44PSTD	44	STD	8	43.22 - 43.82	1097.8 - 1113.0	42.92	1090.2	0.30	7.6	2	1.69	42.9	5395	2445	34.50	876.3	18.71	475.2	13.65	346.7	27.21	691.1	650	45	2
GTMAX-44PXS	44	XS	8	42.72 - 43.32	1085.1 - 1100.3	42.42	1077.5	0.30	7.6	2	1.69	42.9	5370	2433	34.50	876.3	18.71	475.2	13.65	346.7	27.21	691.1	650	45	2
GTMAX-46PSTD	46	STD	8	45.22 - 45.82	1148.6 - 1163.8	44.92	1141.0	0.30	7.6	2	1.69	42.9	4675	2118	35.00	889.0	18.71	475.2	13.65	346.7	27.71	703.8	625	43	2
GTMAX-46PXS	46	XS	8	44.72 - 45.32	1135.9 - 1151.1	44.42	1128.3	0.30	7.6	2	1.69	42.9	4645	2105	35.00	889.0	18.71	475.2	13.65	346.7	27.71	703.8	625	43	2
GTMAX-48PSTD	48	STD	8	47.22 - 47.82	1199.4 - 1214.6	46.92	1191.8	0.30	7.6	2	1.69	42.9	6125	2775	35.00	889.0	18.71	475.2	13.65	346.7	27.71	703.8	600	41	2
GTMAX-48PXS	48	XS	8	46.72 - 47.32	1186.7 - 1201.9	46.42	1179.1	0.30	7.6	2	1.69	42.9	5990	2714	35.00	889.0	18.71	475.2	13.65	346.7	27.71	703.8	600	41	2

Questions? Contact EST Group Customer Service at any of the following locations.



EST Group  
[www.cw-estgroup.com](http://www.cw-estgroup.com)

**North, Central & South America**  
EST Group Corporate Office  
2701 Township Line Road  
Hatfield, PA 19440-1770 USA  
P: +1.215.721.1100  
+1.800.355.7044  
F: +1.215.721.1101  
[est-info@curtisswright.com](mailto:est-info@curtisswright.com)

**Europe / Middle East / Africa**  
EST Group B.V.  
Hoorn 312a  
2404 HL Alphen aan den Rijn  
The Netherlands  
P: +31.172.418841  
F: +31.172.418849  
[est-emea@curtisswright.com](mailto:est-emea@curtisswright.com)

**China**  
P +86.400.636.5077  
[est-china@curtisswright.cn](mailto:est-china@curtisswright.cn)

**Singapore**  
P +65.3158.5052  
[est-asia@curtisswright.com](mailto:est-asia@curtisswright.com)