

## Operating Procedures for GripTight® 15.5 SDR & IPS Test Plugs

### WARNING

- ⚠ For proper operation, GripTight plugs must be assembled as shown in Figure 1.
- ⚠ Pressure testing is inherently dangerous. Strict adherence to these operation instructions and industry safety practices could prevent injury to personnel.
- ⚠ All personnel must be clear of test plug when pressure testing.
- ⚠ The Plastic Pipe Institute (PPI) recommends using an incompressible liquid such as water as the test medium. When using alternative test mediums (air, non-combustible gases, etc.), additional safety precautions need to be taken to protect personnel and equipment from pipe system rupture.
- ⚠ Pipe system pressure testing is performed to discover unacceptable faults in a piping system and may cause such faults to fail by leaking or rupturing. Pipe system ruptures may result in sudden, forcible, uncontrolled movement of system piping, components and/or parts of components.
- ⚠ The pipe system under test and any closures in the test section should be restrained against sudden, uncontrolled movement from catastrophic failure.
- ⚠ Test equipment should be examined before pressure is applied to ensure that it is tightly connected.
- ⚠ All low pressure filling lines and other items not subject to the test pressure should be disconnected or isolated.
- ⚠ Take suitable precautions to eliminate hazards to personnel near lines being tested. Keep personnel a safe distance away from the test section during testing.

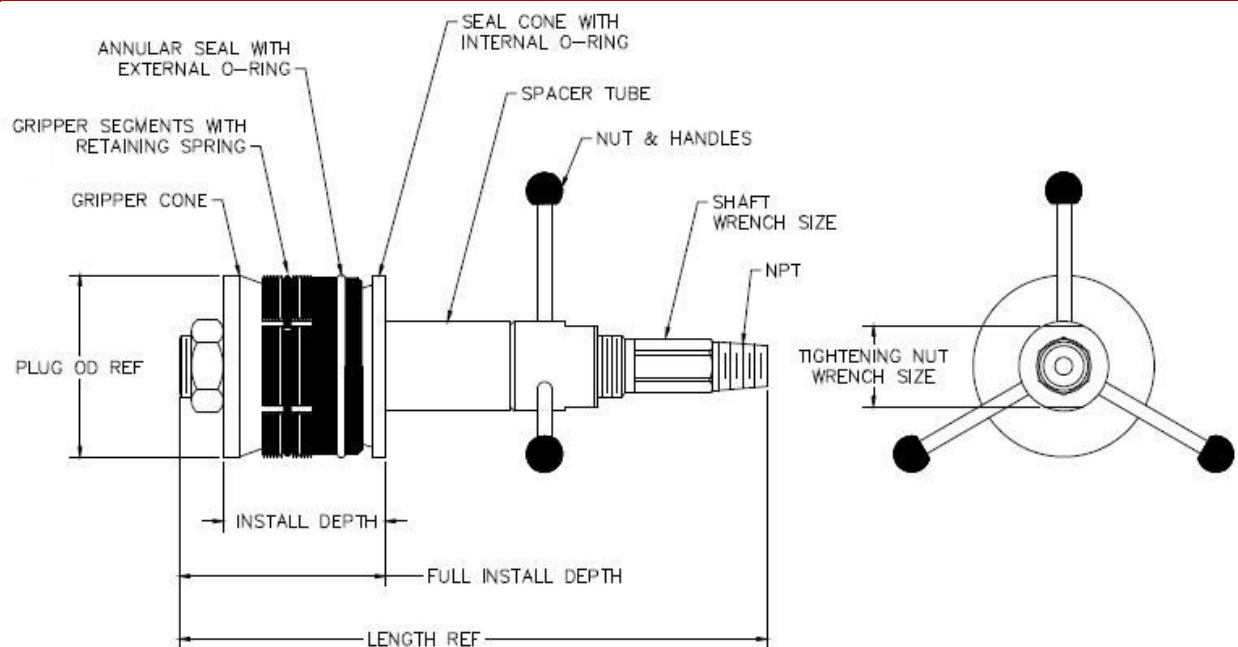
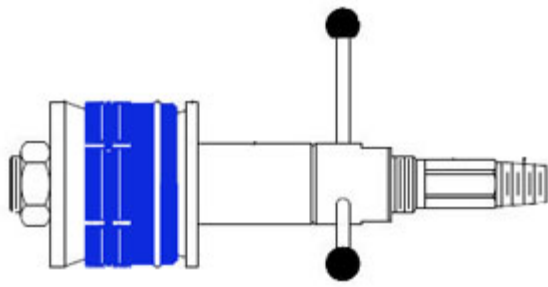
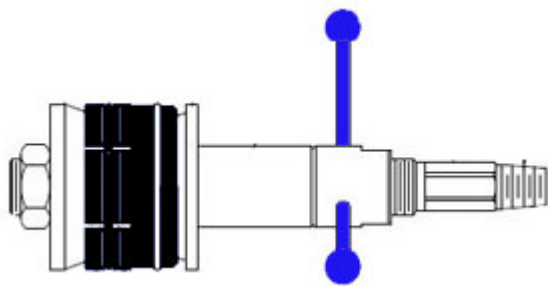

Figure 1: GripTight PE Plug

## 1. Test Preparation

Step/Action	Additional Action/Information/Result
<p>1. Inspect, then replace damaged or worn grippers and seal, if necessary.</p>	 <ul style="list-style-type: none"> <li>Verify that the External O-ring on seal is seated correctly in the groove and that the O-ring is not damaged. The surface between the cone and grippers must be free of friction producing dirt or corrosion.</li> </ul>
<p>2. Verify proper operation of the test plug by rotating the handles clockwise, tightening the nut so that the grippers move freely to the end of the tapered cone surface.</p>	 <ul style="list-style-type: none"> <li>If the nut cannot be easily advanced to allow full gripper expansion, DO NOT USE THIS PLUG FOR TESTING and contact EST Group Customer Service.</li> </ul>
<p>3. Rotate the handles counter-clockwise and fully loosen the nut.</p>	<ul style="list-style-type: none"> <li>Should the grippers not fully retract, apply a light lubricant (i.e. 20 way oil) to the tapered surface of the cone. Wipe away any excess. The threads and both ends of spacer tube should be kept well lubricated with antisieze.</li> </ul>

## 2. Installing a Gag

The use of a gag is mandatory to protect personnel and equipment should something unforeseen occur. There are two options available:

- Safety Gag
- Lightweight PE Gag Assembly

**NOTE:** A Safety Gag is included with your purchase of this plug. Contact EST group Customer Service for inquiries regarding the Lightweight PE Gag Assembly.

## Safety Gag

Perform the steps outlined below to properly install and use the Safety Gag prior to pressure testing.

Step/Action	Additional Action/Information/Result
-------------	--------------------------------------

1. Place the GripTight test plug into the open end of the pipe being tested.
2. Place the Safety Gag over the pipe where the gripper assembly is located.

- The back face of the aluminum seal cone should be approximately  $\frac{3}{4}$ " in from the pipe end.
- See **Table 1** to determine installation depth for your plug.

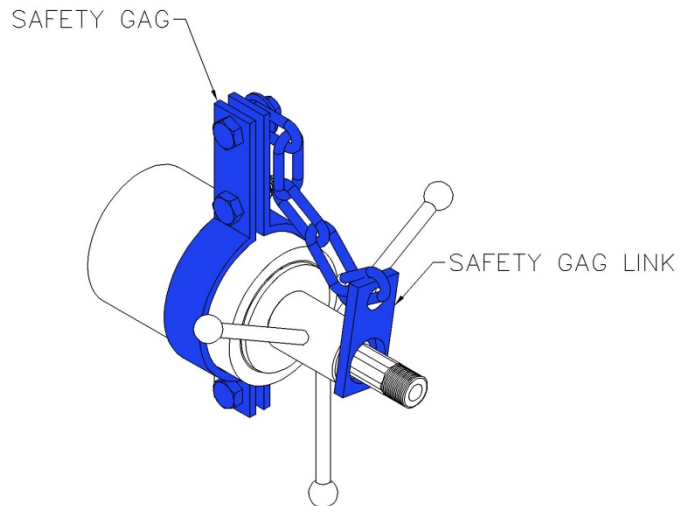

- Tighten bolts to secure Safety gag in place.

## Lightweight PE Gag Assembly

Perform the steps outlined below to properly install and use the Lightweight PE Gag Assembly prior to pressure testing.

Step/Action	Additional Action/Information/Result
-------------	--------------------------------------

1. Slide Gag Plate over the pipe you are testing.

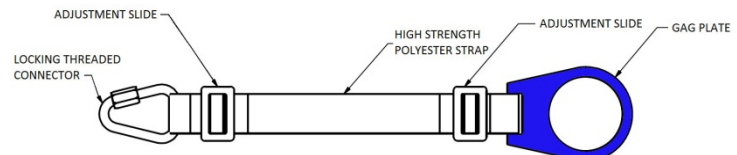

- The Gag Plate must be installed over the pipe where the grippers are located to prevent swelling.

2. Insert the test plug in the pipe.
3. Place the hydrostatic pressure line through the Locking Thread Connector and make connection with the pressure inlet on the test plug.

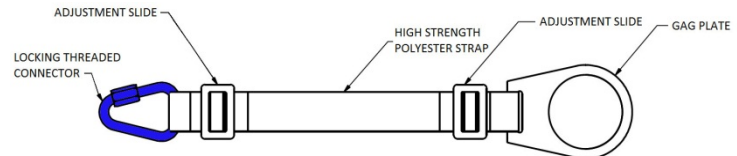

Step/Action	Additional Action/Information/Result
-------------	--------------------------------------

4. Adjust tension in the polyester strap so that there is a small amount of slack.

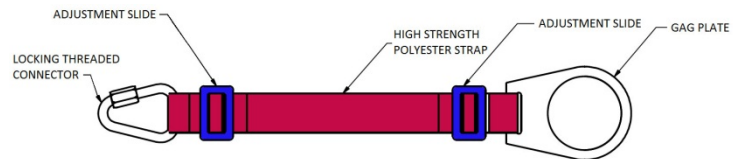

- Slide the gag plate on the pipe until all slack is removed.
- Slide the gag plate towards the test plug approximately 2-4 inches.

If	then
achieving proper slack causes gag plate to be less than 8" away from open end of pipe,	use the adjustment slides to increase effective length of polyester strap and reposition gag plate 8" away from open end of pipe.
gag plate remains less than 8" away from open of pipe after using adjustment slides,	contact EST group for technical assistance.

### 3. Performing the Pressure Test

Step/Action	Additional Action/Information/Result
-------------	--------------------------------------

1. Center the plug within the pipe while rotating the handles, tightening the nut until the test plug has lightly engaged with the pipe ID. At this point the plug will not move relative to the pipe when pushed or pulled by hand.

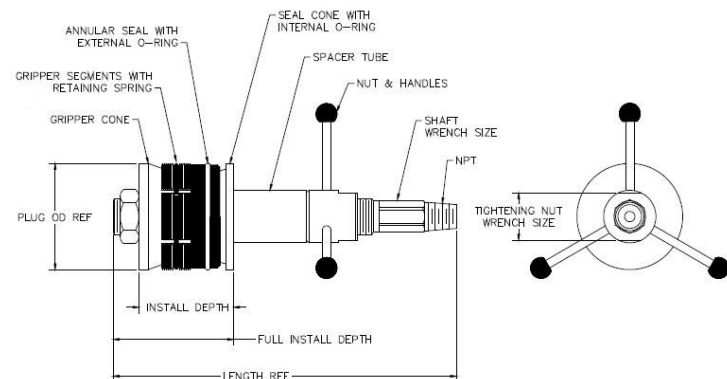

2. Once the plug cannot be moved within the pipe, rotate the handles - a minimum number of turns specified in **TABLE 1**, for the pipe size being tested.

- The amount of turns can be counted by rotating the **RED** knob located on one of the handles.

**NOTE:** The Normal Number of Turns to Engage Seal after the plug has engaged pipe listed in Table 2 is, under normal circumstances, sufficient to seal up the test pressure listed in Table 2 for the appropriate pipe size and material. If the pipe I.D. is at or close to the maximum I.D. tolerance or if defects exist within the I.D. additional turns of the tightening nut may be required.

3. Install the pressure source to the plug leak tight.

- The plug is now ready for pressure testing.

Step/Action	Additional Action/Information/Result
-------------	--------------------------------------

4. Fill the pipe with test medium.

- If hydrostatic testing, all air or gas needs to be vented from the piping system prior to pressurizing.

**NOTE:** As the test pressure is increased the PE pipe will swell slightly at the plug location and along its full length. The swell of the pipe due to internal pressure is an inherent characteristic of the polyethylene material. In most cases the pipe swell is not visible to the naked eye. When the test pressure is released the pipe will return to its original dimension. Neither the GT PE Test Plug nor the pressure test will result in any permanent deformation of the pipe.

5. Slowly introduce the test pressure.

- As pressure increases, the pipe will swell slightly and the seal will be further compressed. Due to this additional seal compression, the shaft will move approximately ¼" from its original installation depth. This is expected.
- Should movement of the shaft or plug exceed approximately ½", release **ALL** pressure immediately, remove plug, examine, re-install and begin testing in accordance with this operating procedure.
- Should movement of the shaft or plug during the test still exceed approximately ½", contact EST Customer Service for technical assistance.

**NOTE:** The test pressure must never exceed the pressures listed for your application in **Table 2**.

6. At the conclusion of the test, release **ALL** pressure.

- Ensure pressure has been released BEFORE rotating the handles counter-clockwise to loosen the nut. Remove and inspect plug. Any plug component, which is worn or damaged, must be replaced before attempting further testing. Contact factory for replacement part information.

TABLE 1

Sales Number	Application	SDR Size/Range	Plug OD		Length		Install Depth		Full Install Depth		Shaft Diameter		NPT	Shaft Hex Flat Wrench Size	Tightening Nut Hex Flat Wrench Size
			(in)	(mm)	(in)	(mm)	(in)	(mm)	(in)	(mm)	(in)	(mm)			
GT-2SDR-155	2" IPS	15.5	1.91	48.514	9	228.6	4 3/8	111.1	4 5/8	117.5	3/8	9.5	1/8	9/16	7/8
	PE PIPE														
	ASTM D2513														
GT-3SDR-155	3" IPS	15.5	2.83	71.9	10 5/8	269.9	4 7/8	123.8	5 3/8	136.5	5/8	15.9	1/4	1/2	1 1/8
	PE PIPE														
	ASTM D2513														
GT-4SDR-155	4" IPS	15.5	3.64	92.5	16 1/8	409.6	5 5/8	141.5	6 1/2	165.1	1 1/4	31.8	4/8	1	15/8
	PE PIPE														
	ASTM D2513														
GT-6SDR-155	6" IPS	15.5	5.35	136	16 1/8	409.6	7 1/4	184.2	8 3/16	208.0	1 1/4	31.8	4/8	1	15/8
	PE PIPE														
	ASTM D2513														
GT-8SDR-155	8" IPS	15.5	6.99	177.5	16 1/8	409.6	7 3/4	196.9	8 11/16	220.7	1 1/4	31.8	4/8	1	15/8
	PE PIPE														
	ASTM D2513														



**EST Group**  
2701 Township Line Rd  
Hatfield, PA 19440-1770 USA  
(P) 215.721.1100  
800.355.7044  
(F) 215.721.1101  
est-info@curtisswright.com  
http://estgroup.cwfc.com

**Europe / Middle East / Africa**  
EST Group B.V.  
Hoor 312a  
2404 HL Alphen aan den Rijn  
The Netherlands  
(P) +31.172.418841  
(F) +31.172.418849  
est-emea@curtisswright.com

**Asia**  
EST Group Asia  
35 Tannery Rd, #11-10 Tannery Block  
Ruby Industrial Complex  
Singapore 247740  
(P) +65.6745.8560  
(F) +65.6742.8700  
est-asia@curtisswright.com

TABLE 2													
Part Number	Application	SDR Size/Range	PE 2406 Maximum Test Pressure (Yellow Pipe)		PE 3408 Maximum Test Pressure (Black Pipe)		PE 4710 Maximum Test Pressure (Black Pipe)		Pipe ID Range		Pipe ID Range		Normal # of Turns to Engage Seal After Plug has Engaged Pipe
			PSIG	BARG	PSIG	BARG	PSIG	BARG	MIN (in)	MAX (in)	MIN (mm)	MAX (mm)	
GT-2SDR-155	2" IPS	15.5	135	9.3	165	11.3	207	14.2	1.93	2.12	49	53.8	16
	PE PIPE ASTM D2513												
GT-3SDR-155	3" IPS	15.5	135	9.3	165	11.3	207	14.2	2.85	3.12	72.4	79.2	15
	PE PIPE ASTM D2513												
GT-4SDR-155	4" IPS	15.5	135	9.3	165	11.3	207	14.2	3.68	3.99	93.5	101.3	7
	PE PIPE ASTM D2513												
GT-6SDR-155	6" IPS	15.5	135	9.3	165	11.3	207	14.2	5.39	5.91	136.9	150.1	8
	PE PIPE ASTM D2513												
GT-8SDR-155	8" IPS	15.5	135	9.3	165	11.3	207	14.2	7.03	7.67	178.6	194.8	9
	PE PIPE ASTM D2513												

#### 4. Storage

Prior to storing, dry all parts of the plug, lubricate the shaft threads and lightly lube the cone and grippers. Store these instructions with the plug.

#### Questions?

Contact EST Group Customer Service at any of the following locations with questions.

- In USA and Canada: tel: 800-355-7044, fax: 215-721-1101, e-mail: [est-info@curtisswright.com](mailto:est-info@curtisswright.com)
- In Europe: tel: +31-172-418841, fax: +31-172-418849; e-mail: [est-emea@curtisswright.com](mailto:est-emea@curtisswright.com)
- In Asia: tel: +65-6745-8560, fax: +65-6742-8700, e-mail: [est-asia@curtisswright.com](mailto:est-asia@curtisswright.com)
- On the Internet: <http://estgroup.cwfc.com>

EST Group provides a complete range of repair products, services and replacement parts covering the life cycle of tubular heat exchangers and condensers; additionally EST Group provides products and services to facilitate pressure testing pipe, piping systems, pressure vessels and their components. Visit EST Group on the Internet at <http://estgroup.cwfc.com>.



**EST Group**  
2701 Township Line Rd  
Hatfield, PA 19440-1770 USA  
(P) 215.721.1100  
800.355.7044  
(F) 215.721.1101  
[est-info@curtisswright.com](mailto:est-info@curtisswright.com)  
<http://estgroup.cwfc.com>

**Europe / Middle East / Africa**  
EST Group B.V.  
Hoor 312a  
2404 HL Alphen aan den Rijn  
The Netherlands  
(P) +31.172.418841  
(F) +31.172.418849  
[est-emea@curtisswright.com](mailto:est-emea@curtisswright.com)

**Asia**  
EST Group Asia  
35 Tannery Rd, #11-10 Tannery Block  
Ruby Industrial Complex  
Singapore 247740  
(P) +65.6745.8560  
(F) +65.6742.8700  
[est-asia@curtisswright.com](mailto:est-asia@curtisswright.com)