

Socket Weld SQS Hydrostatic Test Plug

Eliminate welding in pipe stubs or pups and end caps

Socket Weld SQS plugs facilitate pressure testing systems incorporating 3,000 pound socket weld fittings. SQS plugs eliminate the need to weld in pipe stubs or pups and end caps.

Easy operation. Insert the SQS plug into the socket weld fitting and tighten the large compression nut. The full disk seal expands to seal the bore of the fitting. The grippers expand into the socket area of the fitting to restrain the test plug. Attach a high pressure water supply to the plug and begin testing.

Safe

Unique "Twin Cone" design provides uniform gripper expansion that ensures 100% contact between the test plug and the socket weld fitting.

Pressure rated up to 5,000 PsiG (343 BarG)

Effective

Long wearing urethane seals provide easy plug installation and removal.

Reliable

Replacement grippers and seals available, allowing you to use the SQS hydrostatic test plug multiple times.



EST Group serves the power generation, refining, chemical, pharmaceutical and offshore industries worldwide. QA Program certified to ISO-9001.

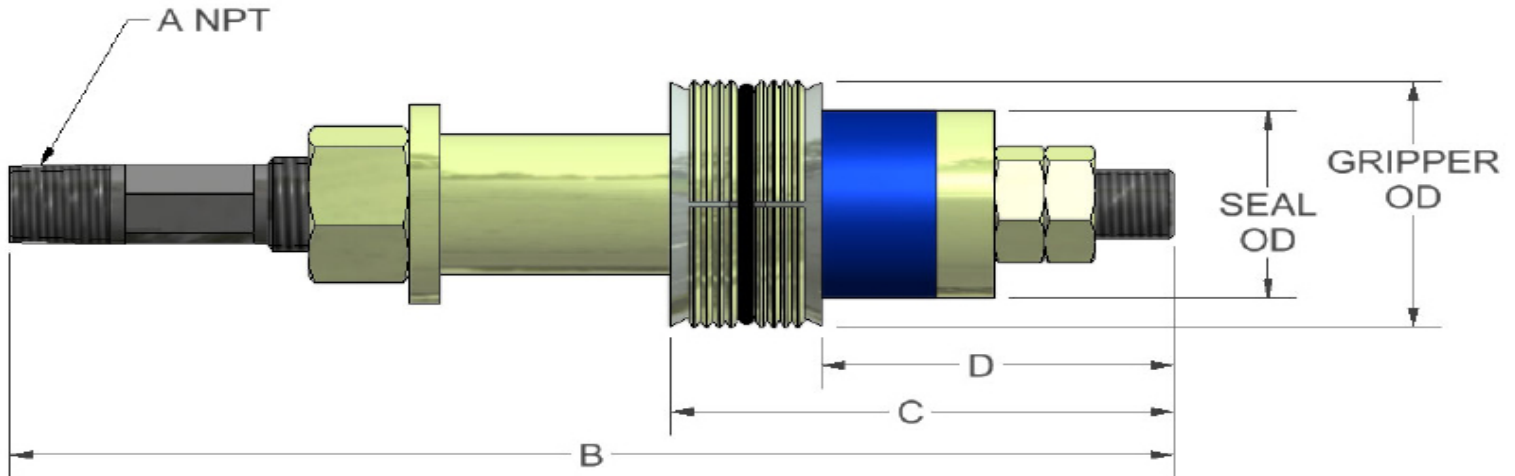

SOCKET WELD OUTLET SIZE IN (MM)	PART NUMBER	MAXIMUM PSIG (BAR)	SHAFT DIAMETER IN (MM)	SEAL OD IN (MM)	GRIPPER OD IN (MM)	"A" NPT CONNECTION	SHAFT ID IN (MM)	"B" PLUG LENGTH IN (MM)	"C" ENGAGEMENT LENGTH IN (MM)	"D" SEALING LENGTH IN (MM)	SHIPPING WEIGHT LBS/KG
1/2 (12.7)	SQS-0086-U	5000 (345)	1/2"-1/4" (6.3)	0.59" (15.0)	0.82" (20.8)	1/8" (3.2)	1/8" (3.2)	5 1/16" (128.6)	1 11/16" (42.9)	1 1/8" (28.6)	0.4/0.2
3/4 (19.0)	SQS-0107-U	5000 (345)	1/2"-3/8" (9.5)	0.79" (20.0)	1.03" (26.2)	1/8" (3.2)	1/8" (3.2)	5 1/16" (128.6)	1 13/16" (46.0)	1 3/16" (30.2)	0.4/0.2
1 (25.4)	SQS-0133-U	4800 (331)	1/2"-3/8" (9.5)	1.00" (25.4)	1.30" (33.0)	1/8" (3.2)	1/8" (3.2)	5 1/16" (128.6)	1 15/16" (49.2)	1 1/4" (31.8)	0.4/0.2
1 1/4 (31.2)	SQS-0168-U	4000 (276)	7/8" (22.2)	1.33" (33.8)	1.62" (41.1)	3/8" (3.2)	7/16" (11.1)	4 5/8" (117.5)	1 5/8" (41.3)	7/8" (22.2)	0.9/0.4
1 1/2 (38.1)	SQS-0192-U	3600 (248)	7/8" (22.25)	1.56" (39.6)	1.87" (47.5)	3/8" (9.5)	7/16" (11.1)	4 5/8" (117.5)	1 13/16" (46.0)	7/8" (22.2)	1.1/0.5
2 (50.8)	SQS-0241-U	3500 (241)	7/8" (22.2)	2.01" (51.1)	2.36" (59.9)	3/8" (9.5)	7/16" (11.1)	4 5/8" (117.5)	1 5/8" (41.3)	7/8" (22.2)	1.3/0.6
2 1/2 (63.5)	SQS-0291-U	3300 (228)	7/8" (22.2)	2.41" (61.2)	2.85" (72.4)	3/8" (9.5)	7/16" (11.1)	4 5/8" (117.5)	1 15/16" (49.2)	7/8" (22.2)	1.3/0.6
3 (76.2)	SQS-0354-U	2900 (200)	1 1/4" (31.7)	3.01" (76.3)	3.47" (88.1)	1/2" (12.7)	9/16" (14.3)	6 3/4" (171.5)	2 1/4" (57.2)	1" (25.4)	3.2/1.5
3 1/2 (88.9)	SQS-0404-U	2700 (186)	1 1/4" (31.7)	3.49" (88.6)	3.98" (101.1)	1/2" (12.7)	9/16" (14.3)	6 3/4" (171.5)	2 3/8" (60.3)	1" (25.4)	3.5/1.6
4 (101.6)	SQS-0455-U	2500 (172)	1 1/4" (31.7)	3.96" (100.6)	4.45" (113.0)	1/2" (12.7)	9/16" (14.3)	6 3/4" (171.5)	2 15/16" (50.8)	1" (25.4)	3.9/1.8
5 (127.0)	SQS-0562-N	2300 (158)	1 1/2" (38.1)	4.98" (126.5)	5.55" (141.0)	3/4" (19.0)	3/4" (19.1)	7 3/8" (187.3)	2 15/16" (74.6)	1 1/4" (31.8)	6.8/3.1

North, Central & South America EST Group 2701 Township Line Road Hatfield, PA 19440-1770 USA | +1.215.721.1100 +1.800.355.7044 | est-info@curtisswright.com

Europe / Middle East / Africa EST Group B.V. Hoorn 312a 2404 HL Alphen aan den Rijn The Netherlands | +31.172.418841 | est-emea@curtisswright.com

China +86.400.636.5077 | est-china@curtisswright.cn | Singapore +65.3158.5052 | est-asia@curtisswright.com