

OPERATING PROCEDURES FOR DOUBLE BLOCK AND BLEED PLUGS - INTERNATIONAL***WARNING!***

- ***PRESSURE TESTING IS INHERENTLY DANGEROUS. STRICT ADHERENCE TO THESE OPERATING INSTRUCTIONS AND INDUSTRY SAFETY PRACTICES COULD PREVENT INJURY TO PERSONNEL.***
- ***ALL PERSONNEL MUST BE CLEAR OF TEST PLUG WHEN PRESSURE TESTING.***
- ***FOR SAFETY, AN INCOMPRESSIBLE LIQUID SUCH AS WATER SHOULD BE USED AS THE TEST MEDIUM. RESIDUAL AIR OR GAS IS TO BE EVACUATED FROM THE PIPE PRIOR TO TESTING.***

PRIOR TO INSTALLATION

1. Visually inspect the plug for worn or damaged components. Replace worn or damaged components as needed.
2. To insure that all installation torque is transmitted to the seal, liberally spread antiseize over both sides of the hardened washer(s) and onto the threads of the shaft(s). Use caution when applying the lubricant and handling the test plug after lubrication. The lubricant must not come in contact with the seals or tube ID.

WARNING! FAILURE TO USE ANTISEIZE MAY CAUSE AN INCOMPLETE TORQUE TRANSMITTAL, WHICH WILL RESULT IN A DECREASE IN THE PRESSURE RATING.

3. Verify that stamping on the plug is equivalent to the pipe size being tested. The plug should be stamped with the pipe size and pipe schedule. Example: The stamp "15P80" should be interpreted as 1-1/2" Sch 80 pipe sizes. The seal OD should agree with the Plug OD listed in Tables 1 & 2 for the corresponding pipe size.
4. Complete Site safety standard checklist.
5. Prior to installing the plug, clean and dry the pipe ID. Remove all moisture, debris and excessive scale from the pipe ID.
6. Connect pressure source to the pressure connection in order to pressurize between seals for isolation and/or test purposes.
7. Install the plug so both seals are inside the pipe. When using the plug as an isolation and/or welding plug position the plug so that the seals are at least 12" from the weld location. When testing the weld position the plug so that the seals straddle the weld or area to be tested.

TIGHTENING AND EXPANSION OF SEAL ELEMENT

8. Correctly tightening the hex nut(s) to the prescribed torque is critical to the operation of the Double Block & Bleed Plug. A leak of the seal is usually an indication that the hex nut(s) was not adequately tightened. The normal torque values listed in Tables 1 & 2 should be adequate for most installations, however due to variations within the pipe ID finishes the torque may need to be increased up to the maximum torque values listed in Tables 1 & 2. If at the maximum torque the plug still leaks, verify the correct seal and washers are being used, correct if necessary, reinstall and torque the plug in increasing increments starting at the normal installation torque.

For Sizes 3/4" to 3" (See Figures 1 & 2)

9. Tighten hex nut to normal installation torque listed in Table 1 using a calibrated torque wrench. If shaft spins while hex nut is being tightened, a crowsfoot and a pipe wrench/opened end wrench must be used. After initial tightening it may be possible to use a deep socket as the friction created when the seals contact the pipe ID will prevent the shaft from spinning during further tightening of the hex nut. (See Table 1 for crowsfoot sizes.)



EST Group
2701 Township Line Rd
Hatfield, PA 19440-1770 USA
(P) 215.721.1100
800.355.7044
(F) 215.721.1101
est-info@curtisswright.com
http://estgroup.cwfc.com

Europe / Middle East / Africa
EST Group B.V.
Hoon 312a
2404 HL Alphen aan den Rijn
The Netherlands
(P) +31.172.418841
(F) +31.172.418849
est-emea@curtisswright.com

Asia
EST Group Asia
35 Tannery Rd, #11-10 Tannery Block
Ruby Industrial Complex
Singapore 247740
(P) +65.6745.8560
(F) +65.6742.8700
est-asia@curtisswright.com

For Sizes 4" to 24" (See Figure 3)

10. Tighten the hex nuts by hand to remove any slack from the parts. Then use a socket wrench capable of producing the torque value listed in Table 2. A socket is required (See Table 2 for socket sizes). Tightening the bottom hex nuts first will aid in centering the plug. If the plug spins during tightening, remove the plug from the pipe. Then tighten the hex nuts to expand the seal slightly and place the plug back into the pipe. This will create a larger contact/friction surface between the plug and the pipe, which should stop the plug from rotating. Once the seals have fully contacted the pipe ID then the hex nuts must be tightened in a star pattern. Complete installation by using a calibrated torque wrench to ensure that the hex nuts have been tightened to the proper torque.

WARNING! FAILURE TO APPLY THE INSTALLATION TORQUE SPECIFIED IN TABLES 1 & 2 COULD RESULT IN UNSAFE OPERATION OR LEAKAGE. INSTALLATION EQUIPMENT AND TOOL MUST BE ADEQUATELY SIZED TO HANDLE INSTALLATION TORQUE.

NOTICE: IF THE PLUG IS INSTALLED FOR MORE THAN A FEW HOURS AT A TIME, THE SEALS MAY EXPERIENCE PERMANENT SEAL DEFORMATION, WHICH WILL RESULT IN AN INCREASED SEAL OD. THE PLUG WILL STILL FUNCTION AS DESIGNED AS LONG AS THE PLUG FITS INTO THE PIPE, HOWEVER EXTRA CARE SHOULD BE TAKEN TO LIMIT INTERNAL WELD REINFORCEMENT TO PREVENT THE PLUG FROM BECOMING LODGED IN THE PIPE.

PRESSURIZATION

11. Prior to pressurizing the system the operator should be aware of the following.
- 11.1 During pressurization there may be some settling of the plug. If at any time during pressurization or testing the test plug moves more than a total of .125" (3mm) the test must be halted and the pressure released immediately. The test plug and pipe ID should be inspected for damage, and the installation procedure should be reviewed prior to reinstalling the plug and retesting. If the situation continues please contact EST Customer Service for technical assistance.

11.2 During pressurization and testing all personnel should remain clear of the test plug and immediate test area.

WARNING! CONSTANTLY MONITOR UPSTREAM PRESSURE. IMMEDIATELY DISCONTINUE WORK IF AN INCREASE IN UPSTREAM PRESSURE OCCURS.

12. Slowly introduce the test pressure. If a pressure decay test will be conducted, it may be necessary to hold at desired pressure with pump for a minimum of 5 minutes prior to closing isolation valve. This will allow parts to settle. Do not exceed the maximum test pressure listed in Tables 1 & 2.
13. If the residual air between the seals must be removed the following technique may be implemented.
- 13.1 Prior to step 7, ensure the port between the seals is at the six o'clock position, then proceed with step 7.
- 13.2 Prior to step 8, tighten the hex nut(s) on the plug until the plug is just snug in the pipe. At this point, the plug should barely be able to slide within the pipe. Then apply slight pressure of the test medium until a small amount of medium escapes past the seals. This technique will push the majority of the residual air out from between the seals. Then proceed with steps 8-12.

PLUG REMOVAL

14. After isolation or testing application is complete, insure all back pressure is released from pipe.
15. Relax the seal by loosening the hex nut(s). Ensure to loosen hex nut(s) until the top of the nut is at the top of the threads. This will prevent permanent seal deformation. When removing plugs with multiple shafts loosen the hex nuts incrementally, using the standard bolting pattern so that the load continues to be distributed over all of the shafts.
16. Withdraw the plug from the tube end.



EST Group
2701 Township Line Rd
Hatfield, PA 19440-1770 USA
(P) 215.721.1100
800.355.7044
(F) 215.721.1101
est-info@curtisswright.com
http://estgroup.cwfc.com

Europe / Middle East / Africa
EST Group B.V.
Hoon 312a
2404 HL Alphen aan den Rijn
The Netherlands
(P) +31.172.418841
(F) +31.172.418849
est-emea@curtisswright.com

Asia
EST Group Asia
35 Tannery Rd, #11-10 Tannery Block
Ruby Industrial Complex
Singapore 247740
(P) +65.6745.8560
(F) +65.6742.8700
est-asia@curtisswright.com

INSPECT PLUG AFTER EACH USE

17. Inspect the plug for wear and replace any worn components. Any component, which is worn or damaged, must be replaced before attempting any further testing. Contact the factory for additional information on the replacement of worn or damaged parts.

WARNING! FAILURE TO REPLACE WORN OR DAMAGED COMPONENTS MAY AFFECT THE ABILITY OF THE PLUG TO HOLD PRESSURE AND MAY CAUSE INJURY OR DAMAGE TO PERSONS OR PROPERTY IN THE TEST AREA.

18. Prior to storing, clean and dry the plug. Re-lubricate the shaft threads and between the hex nut and mating surface as previously described.
19. Store plug in an area out of contact with sun or UV light. UV light will damage and prematurely age the seal elements.

Table 1. Double Block & Bleed Installation Torque Specifications, Sizes 3/4" to 3"

Sales Part Number	Nominal Plug Size	SCH	Plug OD [in (mm)]	Clearance Between Plug & Pipe [in (mm)]	Length [in (mm)]	Distance Between Seals [in (mm)]	Normal Install. Torque [ft-lbs (N-m)]	Maximum Install. Torque [ft-lbs (N-m)]	Crows-foot Size (in)	Maximum Pressure Between Seals [psi (Bar)]	Maximum Upstream Pressure [psi (Bar)]
DBB-75P80	3/4"	80	0.65 (16.5)	0.09 (2.3)	23-1/2 (597)	1.50 (38)	2.5 (3.4)	5.0 (6.8)	7/16	2250 (155)	10 (0.7)
DBB-75P10	3/4"	10	0.78 (19.8)	0.10 (2.5)	23-1/2 (597)	1.50 (38)	4.0 (5.4)	7.0 (9.5)	7/16	2250 (155)	10 (0.7)
DBB-1PXXS / 75P160	1" / 3/4"	XXS / 160	0.54 (13.7)	0.06 (1.5) / 0.07 (1.8)	21-1/2 (546)	1.25 (32)	1.5 (2.0)	3.0 (4.1)	7/16	2250 (155)	10 (0.7)
DBB-1P160 / 75P40	1" / 3/4"	160 / 40	0.72 (18.3)	0.10 (2.5)	23-1/2 (597)	1.50 (38)	3.5 (4.7)	6.5 (8.8)	7/16	2250 (155)	10 (0.7)
DBB-1P80	1"	80	0.84 (21.3)	0.12 (3.0)	23-1/2 (597)	1.50 (38)	4.0 (5.4)	7.0 (9.5)	7/16	2250 (155)	10 (0.7)
DBB-1P40	1"	40	0.93 (23.6)	0.12 (3.0)	23-1/2 (597)	1.50 (38)	5.0 (6.8)	7.0 (9.5)	7/16	2250 (155)	10 (0.7)
DBB-1P10	1"	10	0.98 (24.9)	0.12 (3.0)	23-1/2 (597)	1.50 (38)	5.0 (6.8)	7.5 (10.2)	7/16	2250 (155)	10 (0.7)
DBB-125P160	1-1/4"	160	1.01 (25.7)	0.15 (3.8)	24-3/4 (629)	1.50 (38)	8.0 (10.8)	12 (16.3)	1/2	2250 (155)	10 (0.7)
DBB-125P80	1-1/4"	80	1.13 (28.7)	0.15 (3.8)	24-3/4 (629)	1.50 (38)	10 (13.6)	13 (17.6)	1/2	2250 (155)	10 (0.7)
DBB-125P40	1-1/4"	40	1.23 (31.2)	0.15 (3.8)	24-3/4 (629)	1.50 (38)	11 (14.9)	14 (19.0)	1/2	2250 (155)	10 (0.7)
DBB-125P10	1-1/4"	10	1.29 (32.8)	0.15 (3.8)	24-3/4 (629)	1.50 (38)	12 (16.3)	14 (19.0)	1/2	2250 (155)	10 (0.7)
DBB-15P160	1-1/2"	160	1.19 (30.2)	0.15 (3.8)	27 (686)	2.50 (64)	15 (20)	20 (27)	3/4	2250 (155)	10 (0.7)
DBB-15P40	1-1/2"	40	1.46 (37.1)	0.15 (3.8)	27 (686)	2.50 (64)	15 (20)	20 (27)	3/4	2250 (155)	10 (0.7)
DBB-2PXXS / 15P80	2" / 1-1/2"	XXS / 80	1.35 (34.3)	0.15 (3.8)	27 (686)	2.50 (64)	15 (20)	20 (27)	3/4	2250 (155)	10 (0.7)
DBB-2P160 / 15P10	2" / 1-1/2"	160 / 10	1.53 (38.9)	0.16 (4.1) / 0.15 (3.8)	27 (686)	2.50 (64)	20 (27)	30 (41)	3/4	2250 (155)	10 (0.7)
DBB-2P80	2"	80	1.76 (44.7)	0.18 (4.6)	28-1/2 (724)	2.50 (64)	30 (41)	50 (68)	7/8	2250 (155)	10 (0.7)
DBB-2P40	2"	40	1.89 (48.0)	0.18 (4.6)	28-1/2 (724)	2.50 (64)	30 (41)	50 (68)	7/8	2250 (155)	10 (0.7)
DBB-2P10	2"	10	1.98 (50.3)	0.18 (4.6)	28-1/2 (724)	2.50 (64)	35 (47)	60 (81)	7/8	2250 (155)	10 (0.7)
DBB-25P160	2-1/2"	160	1.95 (49.5)	0.18 (4.6)	28-1/2 (724)	2.50 (64)	35 (47)	60 (81)	7/8	2250 (155)	10 (0.7)
DBB-25P40	2-1/2"	40	2.29 (58.2)	0.18 (4.6)	29 (737)	2.50 (64)	60 (81)	90 (122)	1-1/4	2250 (155)	10 (0.7)
DBB-3PXXS / 25P80	3" / 2-1/2"	XXS / 80	2.13 (54.1)	0.17 (4.3) / 0.19 (4.8)	29 (737)	2.50 (64)	60 (81)	90 (122)	1-1/4	2250 (155)	10 (0.7)
DBB-3P160 / 25P10	3" / 2-1/2"	160 / 10	2.46 (62.5)	0.17 (4.3) / 0.18 (4.6)	33-5/8 (854)	2.50 (64)	100 (136)	150 (203)	1-13/16	2250 (155)	10 (0.7)
DBB-3P80	3"	80	2.69 (68.3)	0.21 (5.3)	33-5/8 (854)	2.50 (64)	150 (203)	200 (271)	1-13/16	2250 (155)	10 (0.7)
DBB-3P40	3"	40	2.86 (72.6)	0.21 (5.3)	33-5/8 (854)	2.50 (64)	150 (203)	200 (271)	1-13/16	2250 (155)	10 (0.7)
DBB-3P10	3"	10	3.04 (77.2)	0.22 (5.6)	33-5/8 (854)	2.50 (64)	175 (237)	250 (339)	1-13/16	2250 (155)	10 (0.7)

Note: For plugs that require torques greater than 91 ft-lbs a high strength crowfoot may be required. EST Group does offer



EST Group
2701 Township Line Rd
Hatfield, PA 19440-1770 USA
(P) 215.721.1100
800.355.7044
(F) 215.721.1101
est-info@curtisswright.com
http://estgroup.cwfc.com

Europe / Middle East / Africa
EST Group B.V.
Hoorn 312a
2404 HL Alphen aan den Rijn
The Netherlands
(P) +31.172.418841
(F) +31.172.418849
est-emea@curtisswright.com

Asia
EST Group Asia
35 Tannery Rd. #11-10 Tannery Block
Ruby Industrial Complex
Singapore 247740
(P) +65.6745.8560
(F) +65.6742.8700
est-asia@curtisswright.com

high strength crowfoot wrenches. Please contact the factory with any inquiries.

Table 2. Double Block & Bleed Installation Torque Specifications, Sizes 4" to 24"

Sales Part Number	Nominal Plug Size	SCH	Plug OD [in (mm)]	Clearance Between Plug & Pipe [in (mm)]	Length [in (mm)]	Distance Between Seals [in (mm)]	Normal Install. Torque [ft-lbs (N-m)]	Maximum Install. Torque [ft-lbs (N-m)]	Deep Socket Size [in]	Maximum Pressure Between Seals [psi (Bar)]	Maximum Upstream Pressure [psi (Bar)]
DBB-4PXXS	4"	XXS	3.00 (76.2)	0.15 (3.8)	6-1/2 (165)	3-1/2 (89)	10 (14)	15 (20)	9/16	2250 (155)	10 (0.7)
DBB-4P160	4"	160	3.29 (83.6)	0.15 (3.8)	6-1/2 (165)	3-1/2 (89)	15 (20)	25 (34)	9/16	2250 (155)	10 (0.7)
DBB-4P120	4"	120	3.48 (88.4)	0.15 (3.8)	6-1/2 (165)	3-1/2 (89)	20 (27)	30 (41)	9/16	2250 (155)	10 (0.7)
DBB-4P80	4"	80	3.63 (92.2)	0.20 (5.1)	6-1/2 (165)	3-1/2 (89)	20 (27)	30 (41)	11/16	2250 (155)	10 (0.7)
DBB-4P40	4"	40	3.83 (97.3)	0.20 (5.1)	6-1/2 (165)	3-1/2 (89)	20 (27)	30 (41)	11/16	2250 (155)	10 (0.7)
DBB-4P10	4"	10	4.06 (103.1)	0.20 (5.1)	6-1/2 (165)	3-1/2 (89)	20 (27)	30 (41)	11/16	2250 (155)	10 (0.7)
DBB-6P160	6"	160	4.99 (126.7)	0.20 (5.1)	9 (229)	4 (102)	70 (95)	110 (149)	1-1/16	2250 (155)	10 (0.7)
DBB-6P120	6"	120	5.30 (134.6)	0.20 (5.1)	9 (229)	4 (102)	80 (109)	120 (163)	1-1/16	2250 (155)	10 (0.7)
DBB-6P80	6"	80	5.56 (141.2)	0.20 (5.1)	9 (229)	4 (102)	80 (109)	130 (176)	1-1/16	2250 (155)	10 (0.7)
DBB-6P40	6"	40	5.87 (149.1)	0.20 (5.1)	9 (229)	4 (102)	90 (122)	140 (190)	1-1/16	2250 (155)	10 (0.7)
DBB-6P10	6"	10	6.16 (156.5)	0.20 (5.1)	9 (229)	4 (102)	90 (122)	140 (190)	1-1/16	2250 (155)	10 (0.7)
DBB-8P160	8"	160	6.56 (167)	0.25 (6.4)	9-3/4 (248)	4 (102)	125 (169)	200 (271)	1-7/16	2250 (155)	10 (0.7)
DBB-8PXXS	8"	XXS	6.63 (168)	0.25 (6.4)	9-3/4 (248)	4 (102)	125 (169)	200 (271)	1-7/16	2250 (155)	10 (0.7)
DBB-8P140	8"	140	6.75 (171)	0.25 (6.4)	9-3/4 (248)	4 (102)	125 (169)	200 (271)	1-7/16	2250 (155)	10 (0.7)
DBB-8P120	8"	120	6.94 (176)	0.25 (6.4)	9-3/4 (248)	4 (102)	125 (169)	200 (271)	1-7/16	2250 (155)	10 (0.7)
DBB-8P100	8"	100	7.19 (183)	0.25 (6.4)	9-3/4 (248)	4 (102)	125 (169)	200 (271)	1-7/16	2250 (155)	10 (0.7)
DBB-8P80	8"	80	7.38 (187)	0.25 (6.4)	9-3/4 (248)	4 (102)	150 (203)	225 (305)	1-5/8	2250 (155)	10 (0.7)
DBB-8P60	8"	60	7.56 (192)	0.25 (6.4)	9-3/4 (248)	4 (102)	175 (237)	250 (339)	1-5/8	2250 (155)	10 (0.7)
DBB-8P40	8"	40/STD	7.73 (196)	0.25 (6.4)	9-3/4 (248)	4 (102)	175 (237)	250 (339)	1-5/8	2250 (155)	10 (0.7)
DBB-8P20	8"	20	7.88 (200)	0.25 (6.4)	9-3/4 (248)	4 (102)	175 (237)	250 (339)	1-5/8	2250 (155)	10 (0.7)
DBB-8P10	8"	10	8.08 (205)	0.25 (6.4)	9-3/4 (248)	4 (102)	175 (237)	250 (339)	1-5/8	2250 (155)	10 (0.7)
DBB-10P100	10"	100	9.06 (230)	0.25 (6.4)	9-3/4 (248)	4 (102)	200 (271)	275 (373)	1-5/8	2250 (155)	10 (0.7)
DBB-10P80	10"	80	9.31 (236)	0.25 (6.4)	9-3/4 (248)	4 (102)	200 (271)	275 (373)	1-5/8	2250 (155)	10 (0.7)
DBB-10PXS	10"	60/XS	9.50 (241)	0.25 (6.4)	9-3/4 (248)	4 (102)	200 (271)	275 (373)	1-5/8	2250 (155)	10 (0.7)
DBB-10P40	10"	40/STD	9.77 (248)	0.25 (6.4)	9-3/4 (248)	4 (102)	225 (305)	300 (407)	1-5/8	2250 (155)	10 (0.7)
DBB-10P10	10"	10	10.17 (258)	0.25 (6.4)	9-3/4 (248)	4 (102)	225 (305)	300 (407)	1-5/8	2250 (155)	10 (0.7)
DBB-12P80	12"	80	11.00 (279)	0.38 (9.7)	9-3/4 (248)	4 (102)	200 (271)	250 (339)	1-5/8	2250 (155)	10 (0.7)
DBB-12P40 / 12PSTD	12"	40 STD	11.62 (295)	0.32 (8.1) 0.38 (9.7)	9-3/4 (248)	4 (102)	225 (305)	275 (373)	1-5/8	2250 (155)	10 (0.7)
DBB-14P80	14"	80	12.12 (308)	0.38 (9.7)	10-1/4(260)	5-1/2 (140)	225 (305)	275 (373)	1-5/8	2250 (155)	10 (0.7)
DBB-14P40	14"	40	12.74 (324)	0.38 (9.7)	10-1/4(260)	5-1/2 (140)	225 (305)	275 (373)	1-5/8	2250 (155)	10 (0.7)
DBB-14PSTD	14"	30/STD	12.87 (327)	0.38 (9.7)	10-1/4(260)	5-1/2 (140)	225 (305)	275 (373)	1-5/8	2250 (155)	10 (0.7)
DBB-16P80	16"	80	13.93 (354)	0.38 (9.7)	10-1/4(260)	5-1/2 (140)	200 (271)	250 (339)	1-5/8	2250 (155)	10 (0.7)
DBB-16P40	16"	40/XS	14.62 (371)	0.38 (9.7)	10-1/4(260)	5-1/2 (140)	225 (305)	275 (373)	1-5/8	2250 (155)	10 (0.7)
DBB-16PSTD	16"	30/STD	14.87 (378)	0.38 (9.7)	10-1/4(260)	5-1/2 (140)	250 (339)	300 (407)	1-5/8	2250 (155)	10 (0.7)
DBB-18P80	18"	80	15.74 (400)	0.38 (9.7)	10-1/4(260)	5-1/2 (140)	250 (339)	300 (407)	1-5/8	2250 (155)	10 (0.7)
DBB-18P40	18"	40	16.50 (419)	0.38 (9.7)	10-1/4(260)	5-1/2 (140)	250 (339)	300 (407)	1-5/8	2250 (155)	10 (0.7)
DBB-18PSTD	18"	STD	16.87 (428)	0.38 (9.7)	10-1/4(260)	5-1/2 (140)	275 (373)	325 (441)	1-5/8	2250 (155)	10 (0.7)
DBB-20P80	20"	80	17.56 (446)	0.38 (9.7)	10-3/4(273)	5-1/2 (140)	225 (305)	275 (373)	1-5/8	2250 (155)	10 (0.7)
DBB-20P40	20"	40	18.43 (468)	0.38 (9.7)	10-3/4(273)	5-1/2 (140)	175 (237)	225 (305)	1-5/8	2250 (155)	10 (0.7)
DBB-20PSTD	20"	20/STD	18.87 (479)	0.38 (9.7)	10-3/4(273)	5-1/2 (140)	225 (305)	275 (373)	1-5/8	2250 (155)	10 (0.7)
DBB-24P80	24"	80	21.18 (538)	0.38 (9.7)	10-3/4(273)	5-1/2 (140)	275 (373)	325 (441)	1-5/8	2250 (155)	10 (0.7)
DBB-24P40	24"	40	22.24 (565)	0.38 (9.7)	10-3/4(273)	5-1/2 (140)	300 (407)	350 (475)	1-5/8	2250 (155)	10 (0.7)
DBB-24PSTD	24"	20/STD	22.87 (581)	0.38 (9.7)	10-3/4(273)	5-1/2 (140)	275 (373)	325 (441)	1-5/8	2250 (155)	10 (0.7)

SEAL AND O-RING INSPECTION AND REPLACEMENT INSTRUCTIONS

INSPECTION

1. Seals should be inspected prior to testing and upon completion of testing.
2. Visually inspect seals for damage. Including cuts, scores, and deformations. Any seal damage that has the potential to cause the plug to fail or leak should be addressed.
3. O-rings do not need to be inspected before and after each use, but if leakage or a pressure drop is noticed o-rings should be inspected at that time and replaced as necessary.
4. O-rings are shown in Figures 1, 2, & 3 for reference. O-rings are designated by ■ in the figures.

SEAL / O-RING REPLACEMENT - DISASSEMBLY

5. When disassembling plugs, be sure to keep track of assembly order. For all plugs start by removing the top hex nut(s) then continue disassembly piece by piece, inspecting each piece as it is removed.
6. Occasionally a flathead screwdriver is required to remove seals. If this is the case be sure not to damage any components while using the flathead screwdriver.

QUESTIONS? Contact EST Group Customer Service at any of the following locations with questions.

In USA and Canada: tel: 800-355-7044, fax: 215-721-1101, e-mail: est-info@curtisswright.com

In Europe: tel: +31-172-418841, fax: +31-172-418849; e-mail: est-emea@curtisswright.com

In Asia: tel: +65-6745-8560, fax: +65-6742-8700, e-mail: est-asia@curtisswright.com

On the Internet: <http://estgroup.cwfc.com>

EST Group is a business unit of Curtiss-Wright Flow Control Company. **EST Group** provides a complete range of repair products, services and replacement parts covering the life cycle of tubular heat exchangers and condensers; additionally EST Group provides products and services to facilitate pressure testing pipe, piping systems, pressure vessels and their components. Visit EST Group on the Internet at <http://estgroup.cwfc.com>.



EST Group
2701 Township Line Rd
Hatfield, PA 19440-1770 USA
(P) 215.721.1100
800.355.7044
(F) 215.721.1101
est-info@curtisswright.com
<http://estgroup.cwfc.com>

Europe / Middle East / Africa
EST Group B.V.
Hoon 312a
2404 HL Alphen aan den Rijn
The Netherlands
(P) +31.172.418841
(F) +31.172.418849
est-emea@curtisswright.com

Asia
EST Group Asia
35 Tannery Rd, #11-10 Tannery Block
Ruby Industrial Complex
Singapore 247740
(P) +65.6745.8560
(F) +65.6742.8700
est-asia@curtisswright.com

Figure 1. Double Block & Bleed, 3/4" to 1 1/4" Plug Sizes

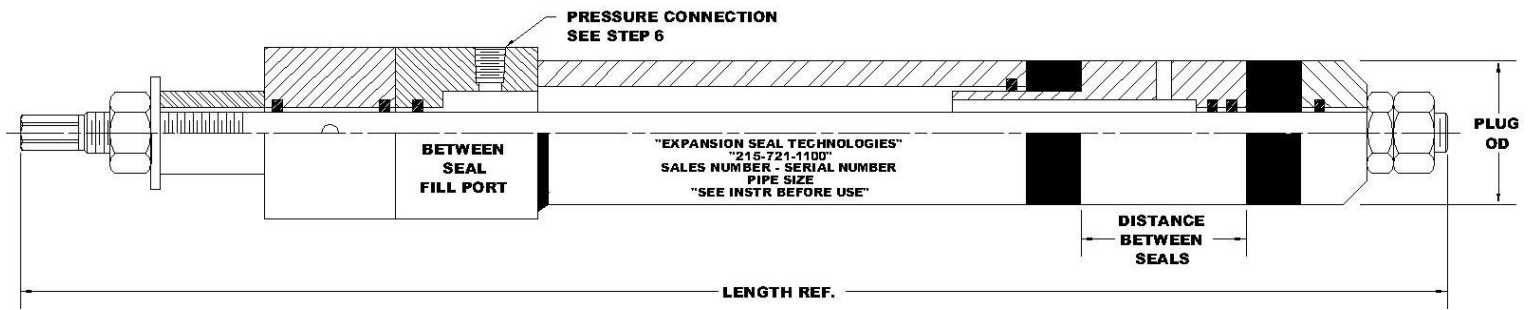

Figure 2. Double Block & Bleed, 1 1/2" to 3" Plug Sizes

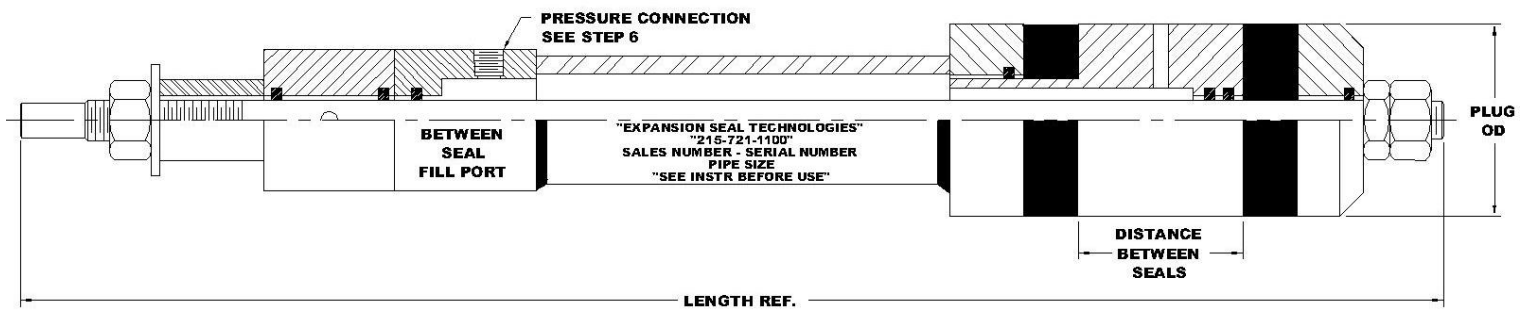
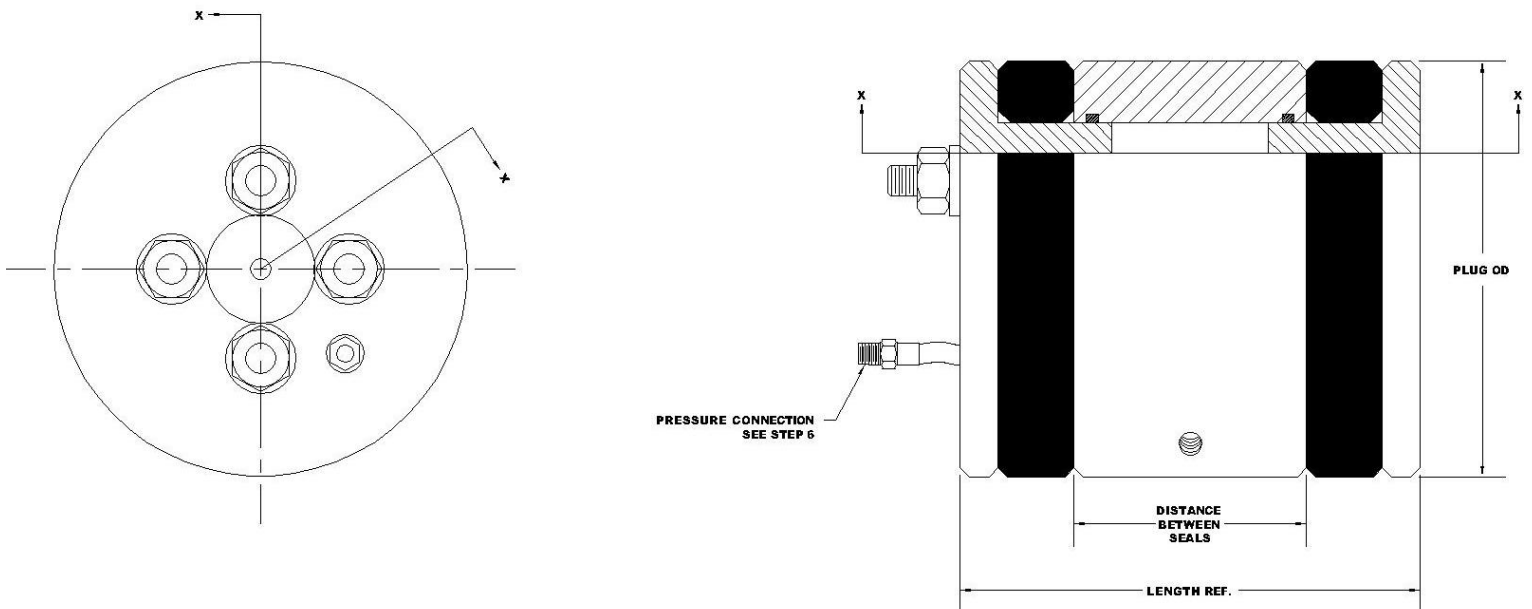

Figure 3. Double Block & Bleed 4" to 24" Plug Sizes



EST Group
 2701 Township Line Rd
 Hatfield, PA 19440-1770 USA
 (P) 215.721.1100
 800.355.7044
 (F) 215.721.1101
 est-info@curtisswright.com
 http://estgroup.cwfc.com

Europe / Middle East / Africa
 EST Group B.V.
 Hoorn 312a
 2404 HL Alphen aan den Rijn
 The Netherlands
 (P) +31.172.418841
 (F) +31.172.418849
 est-emea@curtisswright.com

Asia
 EST Group Asia
 35 Tannery Rd, #11-10 Tannery Block
 Ruby Industrial Complex
 Singapore 247740
 (P) +65.6745.8560
 (F) +65.6742.8700
 est-asia@curtisswright.com