

TUBE STABILIZER (ROD & CABLE TYPE) INSTALLATION PROCEDURES

DESCRIPTION

Tube Stabilizers prevent vibration of fractured or damaged tubes in a heat exchanger. Damage may occur to adjacent tubes if not properly stabilized. The Stabilizer is inserted through the damaged section of the tube and anchored into the tube sheet. The stabilizer extends minimally from the tube sheet, through the fractured or damaged section of tube and through the support plate beyond the fracture. The current stabilizer design (4-1/2" long anchor) allows it to be removed from the tube after it has been installed, if necessary. It also has a stepped down body O.D. to allow it to fit in the unrolled section of tube.

Some tubes, which are fractured, dented or otherwise damaged, may prevent the stabilizer from being installed. In those cases, smaller diameter stabilizers or stabilizing all adjacent tubes should be evaluated. The Stabilizer Anchor is to be installed into the tube in the area where the tube is restrained by the tubesheet. The tube I.D., in the location where the Stabilizer Anchor will be located needs to be clean and free of dirt and debris. The tube I.D., in the location where the Pop-A-Plug will be installed needs to be prepared in accordance with EST document DC4000 and DC4010. Never use Stabilizers in tubes that have more than 0.02" (0.5mm) clearance above the anchor OD.

The stabilizer anchor is not designed to plug off a leaking tube. It is designed to hold the stabilizer rod or cable in place. A Pop-A-Plug is required to be installed in the tubesheet after the anchor, to seal the tube.

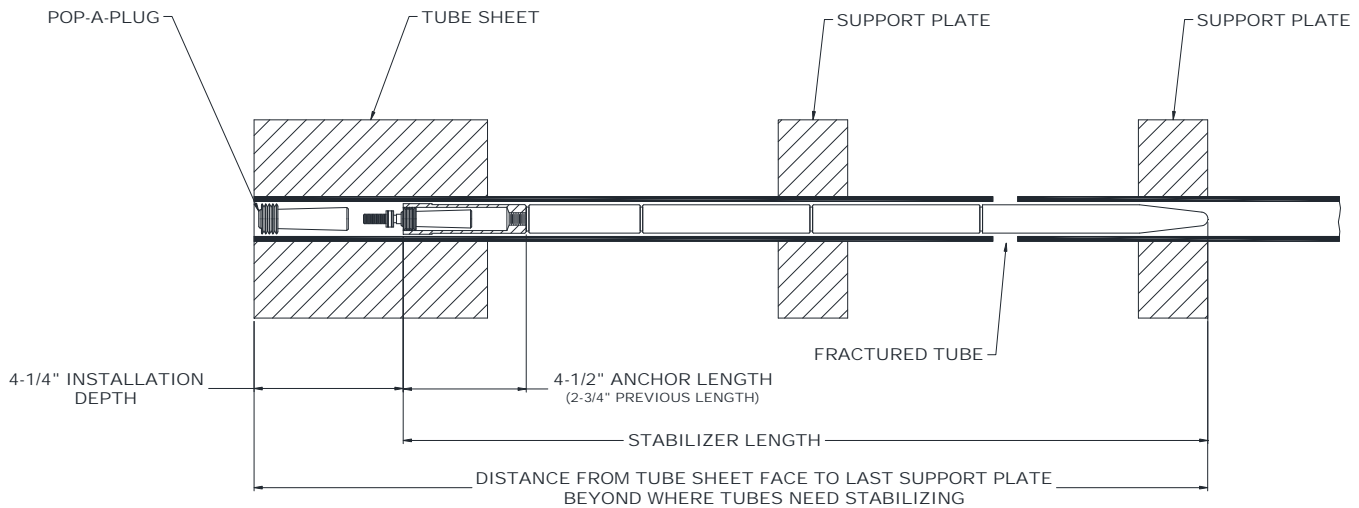

TUBE STABILIZER INSTALLATION REFERENCE

Questions? Contact EST Group Customer Service at any of the following locations.

**CURTISS -
WRIGHT**

EST Group

www.cw-estgroup.com

North, Central & South America

EST Group Corporate Office
2701 Township Line Road
Hatfield, PA 19440-1770 USA
P: +1.215.721.1100
+1.800.355.7044
F: +1.215.721.1101
est-info@curtisswright.com

Europe / Middle East / Africa

EST Group B.V.
Hoorn 312a
2404 HL Alphen aan den Rijn
The Netherlands
P: +31.172.418841
F: +31.172.418849
est-emea@curtisswright.com

China

P +86.400.636.5077
est-china@curtisswright.cn

Singapore

P +65.3158.5052
est-asia@curtisswright.com

ROD INSTALLATION

Remove the thread protecting caps from the Stabilizer Rods and the Tip. Assemble the Tip to Stabilizer Rod by fully engaging the thread and firmly tightening the joint using locking pliers or similar. The lock washer should prevent loosening of the joint. A thread lock compound may be used on each connection as an additional precaution against loosening. If access to the tube is limited, the threaded connections of the stabilizer can be assembled together as the stabilizer is being positioned in the tube.

Repeat step 1 for the remaining connections between Stabilizer Rods until desired length is achieved.

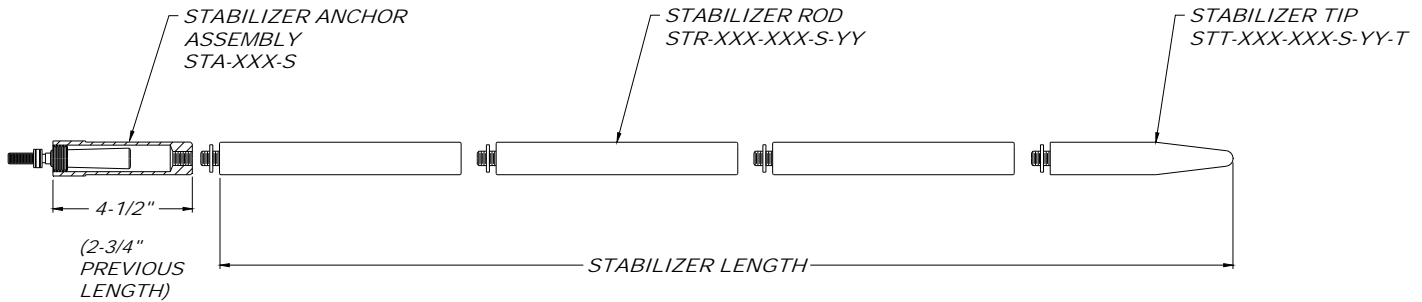

TUBE STABILIZER ROD AND TIP ASSEMBLY

CABLE INSTALLATION

Remove the thread-protecting cap from the Cable assembly. Feed Cable into tube.

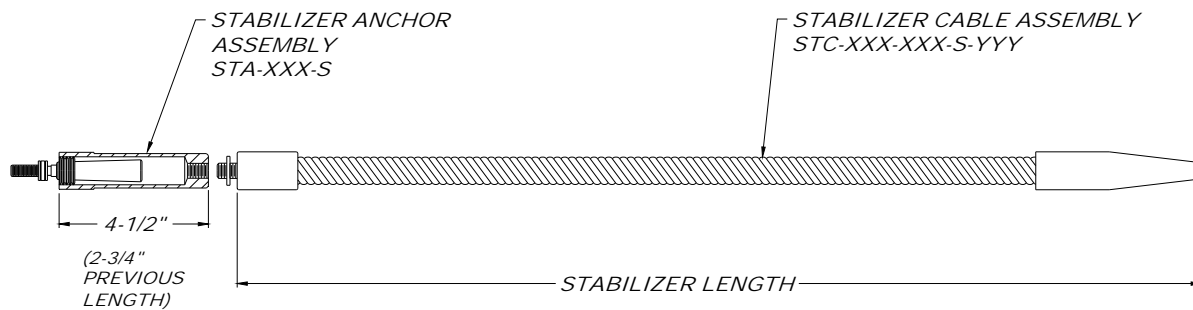

TUBE STABILIZER CABLE ASSEMBLY

Questions? Contact EST Group Customer Service at any of the following locations.

**CURTISS-
WRIGHT**

EST Group
www.cw-estgroup.com

North, Central & South America
EST Group Corporate Office
2701 Township Line Road
Hatfield, PA 19440-1770 USA
P: +1.215.721.1100
+1.800.355.7044
F: +1.215.721.1101
est-info@curtisswright.com

Europe / Middle East / Africa
EST Group B.V.
Hoon 312a
2404 HL Alphen aan den Rijn
The Netherlands
P: +31.172.418841
F: +31.172.418849
est-emea@curtisswright.com

China
P +86.400.636.5077
est-china@curtisswright.cn

Singapore
P +65.3158.5052
est-asia@curtisswright.com

ANCHOR INSTALLATION

Connect Anchor to assembled Stabilizer Rods or Cable assembly. The lock washer should prevent loosening of the joint. A thread lock compound may be used as an additional precaution against loosening. Ensure that compound does not contact outside surface of the Anchor.

Fully engage the exposed thread of the Anchor Assembly into the Channel Head Pull Rod Assembly. (See page 3 for installation equipment). Remove the knurled nut and insert the Pull Rod Assembly through the hydraulic ram - verify that air and hydraulic hoses are fully engaged and tightened. Reattach the knurled nut and firmly tighten to remove slack from the Channel Head Pull Rod Assembly. Ensure the positioner on the Channel Head Pull Rod Assembly is the correct positioner for the Stabilizer Anchor being installed (See Table).

If the tubesheet thickness is 5" (127mm) or greater, the Anchor Assembly is to be positioned so that the near end of the Anchor Assembly is 4.25" (108mm) into the tube. For stabilizing tubes where the tubesheet is less than 5" (127mm), the installation must be reduced to the tube sheet thickness minus 3/4" (19.1mm). For stabilizing tubes where the tube sheet is thinner than 3-1/2" (88.9mm), contact EST Customer Service.

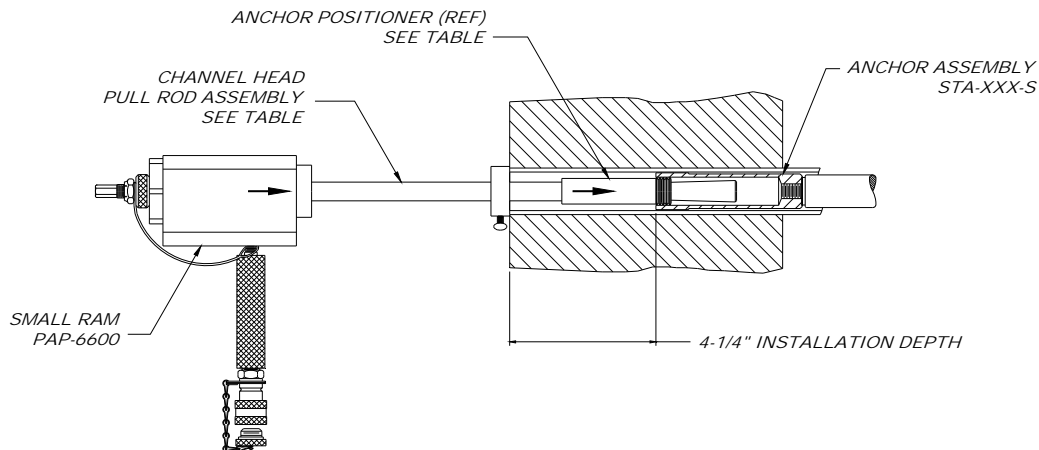

The Anchor is installed when the Breakaway connecting it to the Channel Head Pull Rod Assembly fractures. With the Anchor Assembly at the proper installation depth as indicated above, depress the pump pedal, the ram will stroke. If Breakaway does not fracture and the hydraulic pressure exceeds 7000psi (480 Bar), STOP. Depress front of pump pedal and ram will retract. Tighten the knurled nut and depress the pump pedal. Installation of the Anchor should not require more than two full strokes of the ram. If the Breakaway has not fractured after two full strokes, stop and call EST Group Customer Service for assistance. Remove breakaway stub from end of anchor after installation with a pencil eraser or other means.

WARNING!!! ENSURE PROPER POSITIONER IS USED WHEN INSTALLING ANCHOR ASSEMBLY (SEE TABLE). THIS POSITIONER WILL BE A DIFFERENT SIZE THAN THE ONE USED TO INSTALL THE POP-A-PLUG IN THE TUBE. INSTALL APPROPRIATE POP-A-PLUG IN ACCORDANCE WITH DC4000/DC4010 IN BOTH ENDS OF TUBE

ANCHOR REMOVAL

Please contact EST Group Customer Service for anchor/stabilizer removal tooling or support.

Questions? Contact EST Group Customer Service at any of the following locations.

**CURTISS -
WRIGHT**

EST Group
www.cw-estgroup.com

North, Central & South America
EST Group Corporate Office
2701 Township Line Road
Hatfield, PA 19440-1770 USA
P: +1.215.721.1100
+1.800.355.7044
F: +1.215.721.1101
est-info@curtisswright.com

Europe / Middle East / Africa
EST Group B.V.
Hoorn 312a
2404 HL Alphen aan den Rijn
The Netherlands
P: +31.172.418841
F: +31.172.418849
est-emea@curtisswright.com

China
P +86.400.636.5077
est-china@curtisswright.cn

Singapore
P +65.3158.5052
est-asia@curtisswright.com

EST GROUP

| TUBE ID RANGE (in) | TUBE ID RANGE (mm) | ANCHOR PART NUMBER | ANCHOR THREAD | ROD EXTENSION | | TIP EXTENSION | |
|--------------------|--------------------|--------------------|---------------|---------------|------------------|---------------|--------------------|
| | | | | ROD OD | PART NUMBER | TIP OD | PART NUMBER |
| .501 - .520 | 12.73 - 13.22 | STA-500-S-10 | 10-32 | 7/16 | STR-500-520-S-YY | 7/16 | STT-500-520-S-YY-T |
| .521 - .540 | 13.23 - 13.73 | STA-520-S-10 | 10-32 | 7/16 | STR-500-520-S-YY | 7/16 | STT-500-520-S-YY-T |
| .531 - .550 | 13.49 - 13.97 | STA-530-S-10 | 1/4-28 | 1/2 | STR-530-580-S-YY | 1/2 | STT-530-580-S-YY-T |
| .541 - .560 | 13.74 - 14.24 | STA-540-S-10 | 1/4-28 | 1/2 | STR-530-580-S-YY | 1/2 | STT-530-580-S-YY-T |
| .561 - .580 | 14.25 - 14.75 | STA-560-S-10 | 1/4-28 | 1/2 | STR-530-580-S-YY | 1/2 | STT-530-580-S-YY-T |
| .571 - .590 | 14.50 - 14.99 | STA-570-S-10 | 1/4-28 | 1/2 | STR-530-580-S-YY | 1/2 | STT-530-580-S-YY-T |
| .581 - .600 | 14.50 - 14.99 | STA-580-S-10 | 1/4-28 | 1/2 | STR-530-580-S-YY | 1/2 | STT-530-580-S-YY-T |
| .601 - .620 | 15.27 - 15.76 | STA-600-S-10 | 1/4-28 | 9/16 | STR-600-660-S-YY | 9/16 | STT-600-660-S-YY-T |
| .621 - .640 | 15.77 - 16.27 | STA-620-S-10 | 1/4-28 | 9/16 | STR-600-660-S-YY | 9/16 | STT-600-660-S-YY-T |
| .641 - .660 | 16.28 - 16.78 | STA-640-S-10 | 1/4-28 | 9/16 | STR-600-660-S-YY | 9/16 | STT-600-660-S-YY-T |
| .651 - .670 | 16.54 - 17.02 | STA-650-S-10 | 1/4-28 | 9/16 | STR-600-660-S-YY | 9/16 | STT-600-660-S-YY-T |
| .661 - .680 | 16.79 - 17.27 | STA-660-S-10 | 1/4-28 | 9/16 | STR-600-660-S-YY | 9/16 | STT-600-660-S-YY-T |
| .671 - .690 | 17.04 - 17.53 | STA-670-S-10 | 5/16-24 | 5/8 | STR-670-800-S-YY | 5/8 | STT-670-800-S-YY-T |
| .681 - .700 | 17.28 - 17.79 | STA-680-S-10 | 5/16-24 | 5/8 | STR-670-800-S-YY | 5/8 | STT-670-800-S-YY-T |
| .691 - .710 | 17.55 - 18.01 | STA-690-S-10 | 5/16-24 | 5/8 | STR-670-800-S-YY | 5/8 | STT-670-800-S-YY-T |
| .701 - .720 | 17.80 - 18.30 | STA-700-S-10 | 5/16-24 | 5/8 | STR-670-800-S-YY | 5/8 | STT-670-800-S-YY-T |
| .721 - .740 | 18.31 - 18.81 | STA-720-S-10 | 5/16-24 | 5/8 | STR-670-800-S-YY | 5/8 | STT-670-800-S-YY-T |
| .741 - .760 | 18.82 - 19.32 | STA-740-S-10 | 5/16-24 | 5/8 | STR-670-800-S-YY | 5/8 | STT-670-800-S-YY-T |
| .751 - .770 | 19.08 - 19.56 | STA-750-S-10 | 5/16-24 | 5/8 | STR-670-800-S-YY | 5/8 | STT-670-800-S-YY-T |
| .761 - .780 | 19.33 - 19.83 | STA-760-S-10 | 5/16-24 | 5/8 | STR-670-800-S-YY | 5/8 | STT-670-800-S-YY-T |
| .781 - .790 | 19.84 - 20.34 | STA-780-S-10 | 5/16-24 | 5/8 | STR-670-800-S-YY | 5/8 | STT-670-800-S-YY-T |
| .791 - .810 | 20.09 - 20.57 | STA-790-S-10 | 5/16-24 | 5/8 | STR-670-800-S-YY | 5/8 | STT-670-800-S-YY-T |
| .801 - .820 | 20.35 - 20.84 | STA-800-S-10 | 5/16-24 | 5/8 | STR-670-800-S-YY | 5/8 | STT-670-800-S-YY-T |
| .811 - .830 | 20.60 - 21.08 | STA-810-S-10 | 5/16-24 | 3/4 | STR-810-940-S-YY | 3/4 | STT-810-940-S-YY-T |
| .821 - .840 | 20.85 - 21.35 | STA-820-S-10 | 5/16-24 | 3/4 | STR-810-940-S-YY | 3/4 | STT-810-940-S-YY-T |
| .841 - .860 | 21.36 - 21.86 | STA-840-S-10 | 5/16-24 | 3/4 | STR-810-940-S-YY | 3/4 | STT-810-940-S-YY-T |
| .861 - .880 | 21.87 - 22.37 | STA-860-S-10 | 5/16-24 | 3/4 | STR-810-940-S-YY | 3/4 | STT-810-940-S-YY-T |
| .881 - .900 | 22.38 - 22.87 | STA-880-S-10 | 5/16-24 | 3/4 | STR-810-940-S-YY | 3/4 | STT-810-940-S-YY-T |
| .891 - .910 | 22.63 - 23.11 | STA-890-S-10 | 5/16-24 | 3/4 | STR-810-940-S-YY | 3/4 | STT-810-940-S-YY-T |
| .901 - .920 | 22.88 - 23.38 | STA-900-S-10 | 5/16-24 | 3/4 | STR-810-940-S-YY | 3/4 | STT-810-940-S-YY-T |
| .921 - .940 | 22.39 - 23.87 | STA-920-S-10 | 5/16-24 | 3/4 | STR-810-940-S-YY | 3/4 | STT-810-940-S-YY-T |
| .931 - .950 | 23.65 - 24.13 | STA-930-S-10 | 5/16-24 | 3/4 | STR-810-940-S-YY | 3/4 | STT-810-940-S-YY-T |
| .941 - .960 | 23.88 - 24.10 | STA-940-S-10 | 5/16-24 | 3/4 | STR-810-940-S-YY | 3/4 | STT-810-940-S-YY-T |

| CABLE ASSEMBLY | | 1 FT CHANNEL HEAD PULL ROD ASSEMBLY | ANCHOR POSITIONER (REF) |
|--------------------|-------------------|-------------------------------------|-------------------------|
| CONNECTOR & TIP OD | PART NUMBER | PART NUMBER | PART NUMBER |
| 0.47 | STC-500-520-S-XXX | CHA-400-440-01 | PP-400-440 |
| 0.47 | STC-500-520-S-XXX | CHA-400-440-01 | PP-400-440 |
| 0.51 | STC-530-580-S-XXX | CHA-400-440-01 | PP-400-440 |
| 0.51 | STC-530-580-S-XXX | CHA-400-440-01 | PP-400-440 |
| 0.53 | STC-530-580-S-XXX | CHA-460-500-01 | PP-460-500 |
| 0.53 | STC-530-580-S-XXX | CHA-460-500-01 | PP-460-500 |
| 0.53 | STC-530-580-S-XXX | CHA-460-500-01 | PP-460-500 |
| 0.56 | STC-600-660-S-XXX | CHA-460-500-01 | PP-460-500 |
| 0.56 | STC-600-660-S-XXX | CHA-520-580-01 | PP-520-580 |
| 0.60 | STC-600-660-S-XXX | CHA-520-580-01 | PP-520-580 |
| 0.60 | STC-600-660-S-XXX | CHA-520-580-01 | PP-520-580 |
| 0.66 | STC-670-800-S-XXX | CHA-520-580-01 | PP-520-580 |
| 0.66 | STC-670-800-S-XXX | CHA-520-580-01 | PP-520-580 |
| 0.66 | STC-670-800-S-XXX | CHA-600-680-01 | PP-600-680 |
| 0.66 | STC-670-800-S-XXX | CHA-600-680-01 | PP-600-680 |
| 0.66 | STC-670-800-S-XXX | CHA-600-680-01 | PP-600-680 |
| 0.66 | STC-670-800-S-XXX | CHA-600-680-01 | PP-600-680 |
| 0.66 | STC-670-800-S-XXX | CHA-600-680-01 | PP-600-680 |
| 0.66 | STC-670-800-S-XXX | CHA-600-680-01 | PP-600-680 |
| 0.66 | STC-670-800-S-XXX | CHA-600-680-01 | PP-600-680 |
| 0.75 | STC-670-800-S-XXX | CHA-700-780-01 | PP-700-780 |
| 0.75 | STC-670-800-S-XXX | CHA-700-780-01 | PP-700-780 |
| 0.75 | STC-810-940-S-XXX | CHA-700-780-01 | PP-700-780 |
| 0.75 | STC-810-940-S-XXX | CHA-700-780-01 | PP-700-780 |
| 0.75 | STC-810-940-S-XXX | CHA-700-780-01 | PP-700-780 |
| 0.75 | STC-810-940-S-XXX | CHA-700-780-01 | PP-700-780 |
| 0.85 | STC-810-940-S-XXX | CHA-800-860-01 | PP-800-860 |
| 0.85 | STC-810-940-S-XXX | CHA-800-860-01 | PP-800-860 |
| 0.88 | STC-810-940-S-XXX | CHA-800-860-01 | PP-800-860 |
| 0.88 | STC-810-940-S-XXX | CHA-800-860-01 | PP-800-860 |

The following designates:

All components, part number: S is the material designator, 316 stainless steel

Rod extension part number: YY is the length in inches (Standard Rod length is 12in, 24in, 36in, 48in & 72in)

Tip extension part number: YY is the length in inches (Tip lengths can vary depending on Stabilizer length), T is tip style (B = Bullet, W= Wedge)

Cable assembly part number: XXX is the length in inches

The extended length of the Channel head assembly, allows the installer to properly position the Anchor into the tube to the required installation depth.

Questions? Contact EST Group Customer Service at any of the following locations.



EST Group
www.cw-estgroup.com

North, Central & South America
EST Group Corporate Office
2701 Township Line Road
Hatfield, PA 19440-1770 USA
P: +1.215.721.1100
+1.800.355.7044
F: +1.215.721.1101
est-info@curtisswright.com

Europe / Middle East / Africa
EST Group B.V.
Hoorn 312a
2404 HL Alphen aan den Rijn
The Netherlands
P: +31.172.418841
F: +31.172.418849
est-emea@curtisswright.com

China
P +86.400.636.5077
est-china@curtisswright.cn

Singapore
P +65.3158.5052
est-asia@curtisswright.com