

# HIGH LIFT FLANGE TP/WP (3/4"-4") TECHNICAL SPECIFICATIONS

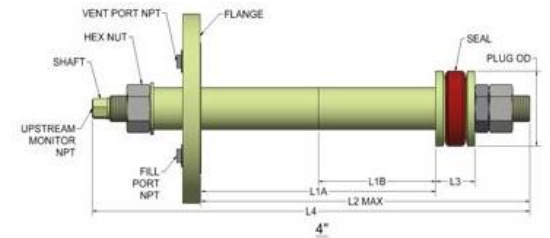
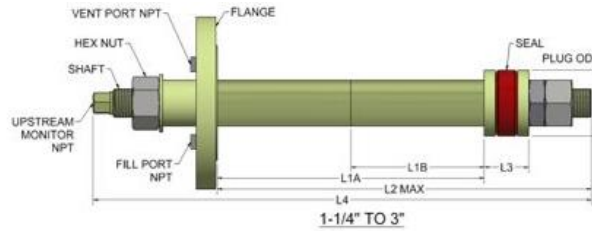
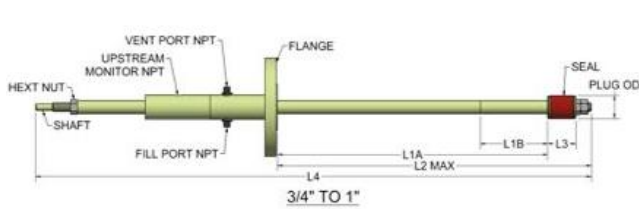

FLANGE SIZE	ANSI FLANGE CLASS	PIPE SCHEDULE	PART NUMBER	PLUG OD		SEAL TO PIPE CLEARANCE		SHAFT OD		SHAFT ID		VENT & FILL PORT SIZE NPT (3)	UPSTREAM MONITOR SIZE NPT (3)	L1A WELDING PLUG		L1B TEST PLUG		L2 MAX		L3		L4		SHAFT HEX SIZE	HEX NUT SIZE	ESTIMATED SHIPPING WEIGHT 150 LB		ESTIMATED SHIPPING WEIGHT 300 LB		ESTIMATED SHIPPING WEIGHT 600 LB	
				in	(mm)	in	(mm)	in	(mm)	in	(mm)			in	(mm)	in	(mm)	in	(mm)	in	(mm)	in	(mm)			in	(mm)	in	(mm)	lb	(kg)
3/4" DN20	150 - 600	160	HL2Z-075P160	.56	14	.05	1.3	3/8	10	3/16	5	1/8 F	1/8 F	12	305	3	76.2	14-1/4	362	1-1/4	31.8	24 11/16	627	N/A (4)	9/16	8	3.62	9	4.08	9	4.08
		80	HL2Z-075P80	.67	17	.07	1.8																								
		40	HL2Z-075P40	.75	19	.07	1.8																								
		10	HL2Z-075P10	.81	21	.07	1.8																								
1" DN25	150 - 600	xxs	HL2Z-1PXXS	.56	14	.04	1.0	3/8	10	3/16	5	1/8 F	1/8 F	12	305	3	76.2	14-1/4	362	1-1/4	31.8	24 11/16	627	N/A (4)	9/16	9	4.08	11	4.98	11	4.98
		160	HL2Z-1P160	.71	18	.11	2.8																								
		80	HL2Z-1P80	.85	22	.11	2.8																								
		40	HL2Z-1P40	.94	24	.11	2.8																								
1-1/4" DN32	150 - 600	160	HL2Z-125P160	1.03	26	.13	3.3	5/8	10	5/16	8	1/8 F	1/4 M	12	305	3-3/8	86	15	381	1-3/4	44.5	20 3/8	518	1/2	15/16	10	4.53	13	5.89	13	5.89
		80	HL2Z-125P80	1.15	29	.13	3.3																								
		40	HL2Z-125P40	1.25	32	.13	3.3																								
		10	HL2Z-125P10	1.33	34	.11	2.8																								
1-1/2" DN40	150 - 600	160	HL2Z-15P160	1.17	30	.17	4.3	5/8	16	5/16	8	1/4 F	1/4 M	12	305	3-3/8	86	15-1/8	384	1-3/4	44.5	20 3/8	518	1/2	15/16	11	4.98	15	6.80	16	7.25
		80	HL2Z-15P80	1.33	34	.17	4.3																								
		40	HL2Z-15P40	1.44	37	.17	4.3																								
		10	HL2Z-15P10	1.51	38	.17	4.3																								
2" DN50	150 - 600	xxs	HL2Z-2PXXS	1.33	34	.17	4.3	5/8	16	5/16	8	1/4 F	1/4 M	12	305	3-3/8	86	15-1/8	384	1-3/4	44.5	20 3/8	518	1/2	15/16	14	6.34	18	8.16	20	9.06
		160	HL2Z-2P160	1.44	37	.25	6.4																								
		80	HL2Z-2P80	1.69	43	.25	6.4																								
		40	HL2Z-2P40	1.82	46	.25	6.4																								
2-1/2" DN65	150 - 600	160	HL2Z-25P160	2.00	51	.13	3.3	1-1/4	32	1/2	13	1/4 F	3/8 F	12	305	6	152	17-1/8	435	2	50.8	22 3/8	568	7/8	2	20	9.06	25	11.33	28	12.69
		80	HL2Z-25P80	2.07	53	.25	6.4																								
		40	HL2Z-25P40	2.22	56	.25	6.4																								
		10	HL2Z-25P10	2.39	61	.25	6.4																								
3" DN80	150 - 600	xxs	HL2Z-3PXXS	2.07	53	.23	5.8	1-1/4	32	1/2	13	3/4 F	3/8 F	12	305	6	152	17-1/8	435	2	50.8	22 3/8	568	7/8	2	26	11.78	33	14.95	37	16.76
		160	HL2Z-3P160	2.25	57	.38	9.7																								
		80	HL2Z-3P80	2.52	64	.38	9.7																								
		40	HL2Z-3P40	2.69	68	.38	9.7																								
4" DN100	150 - 600	xxs	HL2Z-4PXXS	2.71	69	.44	11.2	1-1/4	32	1/2	13	3/4 F	3/8 F	12	305	6	152	17-1/8	435	2	50.8	22 3/8	568	7/8	2	32	14.50	43	19.48	56	25.37
		160	HL2Z-4P160	3.00	76	.44	11.2																								
		120	HL2Z-4P120	3.19	81	.44	11.2																								
		80	HL2Z-4P80	3.39	86	.44	11.2																								
		40	HL2Z-4P40	3.59	91	.44	11.2																								
		10	HL2Z-4P10	3.81	97	.45	11.4																								

Z = A = 150lb = 450 PsiG (31.0 BarG)  
 Z = B = 300lb = 1,125 PsiG (77.6 BarG)  
 Z = D = 600lb = 2,250 PsiG (155 BarG)

(1) Standard Seal Material = Urethane  
 (2) Male NPT = M, Female NPT = F  
 (3) 3/4"-1" has round section for use of pipe wrench

**Questions? Contact EST Group Customer Service at any of the following locations.**



EST Group  
[www.cw-estgroup.com](http://www.cw-estgroup.com)

**North, Central & South America**

EST Group Corporate Office  
 2701 Township Line Road  
 Hatfield, PA 19440-1770 USA  
 P: +1.215.721.1100  
 +1.800.355.7044  
 F: +1.215.721.1101  
[est-info@curtisswright.com](mailto:est-info@curtisswright.com)

**Europe / Middle East / Africa**

EST Group B.V.  
 Hoorn 312a  
 2404 HL Alphen aan den Rijn  
 The Netherlands  
 P: +31.172.418841  
 F: +31.172.418849  
[est-emea@curtisswright.com](mailto:est-emea@curtisswright.com)

**China**

P +86.400.636.5077  
[est-china@curtisswright.cn](mailto:est-china@curtisswright.cn)

**Singapore**

P +65.3158.5052  
[est-asia@curtisswright.com](mailto:est-asia@curtisswright.com)

# HIGH LIFT FLANGE TP/WP (6"-14") TECHNICAL SPECIFICATIONS

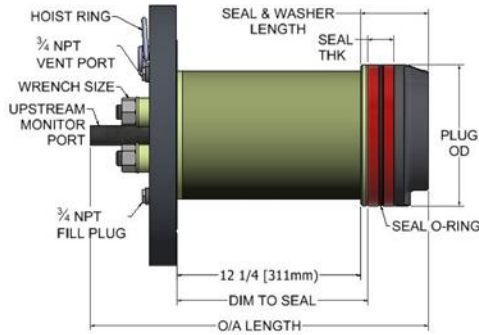

FLANGE SIZE	ANSI FLANGE CLASS (2)	PIPE SCHEDULE	PART NUMBER	BOTTOM WASHER OD (4)		PLUG OD		UPSTREAM MONITOR PORT NPT	SHAFT QTY	HEX NUT SIZE	SEAL THK		DIM TO SEAL		O/A LENGTH		SEAL/WASHER LENGTH		SEAL O-RING DASH NO. (5)	ESTIMATED SHIPPING WEIGHT 150 LB		ESTIMATED SHIPPING WEIGHT 300 LB		ESTIMATED SHIPPING WEIGHT 600 LB		
				(in)	(mm)	in	(mm)				in	(mm)	in	(mm)	in	(mm)	in	(mm)		in	(mm)	lbs	(kg)	lbs	(kg)	lbs
6" DN250	150 - 600	sch 160	HL2Z-6P160	4.69	119	4.69	119	1/2	4	3/4	1	25.4	12-3/4	324	20-1/4	514	3	76.2	N/A	80	36.2	90	40.8	130	58.9	
		sch 120	HL2Z-6P120			5.00	127										3	76.2								
		sch 80	HL2Z-6P80			5.26	134										3	76.2								
		sch 40	HL2Z-6P40			5.57	141										3	76.2								
8" DN300	150 - 600	sch 160	HL2Z-8P160	6.31	160	6.31	160	3/4	4	1-1/16	1	25.4	12-3/4	324	20-1/2	521	3 1/4	83	N/A	120	54.4	150	68.0	270	122	
		sch xs	HL2Z-8PXXS			6.38	162										3 1/4	83								
		sch 140	HL2Z-8P140			6.50	165										3 1/4	83								
		sch 120	HL2Z-8P120			6.69	170										3 1/4	83								
		sch 100	HL2Z-8P100			6.94	176										3 1/4	83								
		sch 60	HL2Z-8P60			7.31	186										3 1/4	83								
		sch 80	HL2Z-8P80			7.13	181										3 1/4	83								
		sch 40	HL2Z-8P40			7.48	190										3 1/4	83								
10" DN250	150 - 600	sch 100 (4)	HL2Z-10P100	8.81	224	8.81	224	1	4	1-5/8	1-3/4	44.5	12-3/4	324	22-3/4	578	4 1/2	114	-445	175	79.3	230	104	339	154	
		sch 80	HL2Z-10P80			9.06	230										4 1/2	114								-446
		sch 60xs	HL2Z-10PXS			9.25	235										4 1/2	114								-446
		sch 40/std	HL2Z-10P40			9.52	242										4 1/2	114								-447
		sch 30	HL2Z-10P30			9.64	245										4 1/2	114								-447
		sch 20	HL2Z-10P20			9.75	248										4 1/2	114								-447
		sch 10s	HL2Z-10P10S			9.92	252										4 1/2	114								-448
		sch 5	HL2Z-10P5			9.98	253										4 1/2	114								-448
12" DN300	150 - 600	sch 80 (4)	HL2Z-12P80	10.87	276	10.87	276	1	6	1-5/8	1-3/4	44.5	12-3/4	324	23	584	4 3/4	121	-449	212	96.1	332	150	444	201	
		sch 60	HL2Z-12P60			11.13	283										4 3/4	121								-450
		xs	HL2Z-12PXS			11.25	286										4 3/4	121								-450
		sch40/std	HL2Z-12P40			11.50	292										4 3/4	121								-451
		sch 30	HL2Z-12P30			11.59	294										4 3/4	121								-451
		sch 20	HL2Z-12P20			11.75	298										4 3/4	121								-451
		sch 10s/5	HL2Z-12P10S			11.94	303										4 3/4	121								-452
14" DN350	150 - 600	sch 140 (4)	HL2Z-14P140	11.00	279	11.00	279	1	6	1-5/8	1-3/4	44.5	12-3/4	324	25-3/4	654	4 3/4	121	N/A	296	134	386	175	530	240	
		sch 120	HL2Z-14P120			11.31	287										4 3/4	121								
		sch 100	HL2Z-14P100			11.62	295										4 3/4	121								
		sch 80	HL2Z-14P80			12.00	305										4 3/4	121								
		sch 60	HL2Z-14P60			12.31	313										4 3/4	121								
		xs	HL2Z-14Pxs			12.50	318										4 3/4	121								
		sch 40	HL2Z-14P40			12.62	321										4 3/4	121								
		sch 30/std	HL2Z-14PSTD			12.75	324										4 3/4	121								
		sch 20	HL2Z-14P20			12.88	327										4 3/4	121								
		sch 10/10s/5	HL2Z-14P10			13.12	333										4 3/4	121								

(1) Standard Seal Material = Urethane (3) Seal to pipe clearance is approximately 1/2", clearance may be slightly smaller on plugs that accommodate more than one schedule size.  
 (2) Standard Operating Pressure: (4) 10" & 12" Seals include an external o-ring

Questions? Contact EST Group Customer Service at any of the following locations.



EST Group  
[www.cw-estgroup.com](http://www.cw-estgroup.com)

**North, Central & South America**  
**EST Group Corporate Office**  
 2701 Township Line Road  
 Hatfield, PA 19440-1770 USA  
 P: +1.215.721.1100  
 +1.800.355.7044  
 F: +1.215.721.1101  
[est-info@curtisswright.com](mailto:est-info@curtisswright.com)

**Europe / Middle East / Africa**  
**EST Group B.V.**  
 Hoorn 312a  
 2404 HL Alphen aan den Rijn  
 The Netherlands  
 P: +31.172.418841  
 F: +31.172.418849  
[est-emea@curtisswright.com](mailto:est-emea@curtisswright.com)

**China**  
 P +86.400.636.5077  
[est-china@curtisswright.cn](mailto:est-china@curtisswright.cn)

**Singapore**  
 P +65.3158.5052  
[est-asia@curtisswright.com](mailto:est-asia@curtisswright.com)

# HIGH LIFT FLANGE TP/WP (16"-24") TECHNICAL SPECIFICATIONS

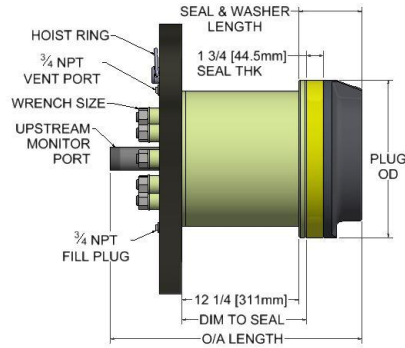

FLANGE SIZE	ANSI FLANGE CLASS (2)	PIPE SCHEDULE	PART NUMBER	BOTTOM WASHER OD (4)		PLUG OD (3) (4)		UPSTREAM MONITOR PORT	SHAFT QTY	HEX NUT SIZE	DIM TO SEAL		O/A LENGTH		SEAL/WASHER LENGTH		ESTIMATED SHIPPING WEIGHT 150 LB		ESTIMATED SHIPPING WEIGHT 300 LB		ESTIMATED SHIPPING WEIGHT 600 LB	
				(in)	(mm)	(in)	(mm)				(in)	(mm)	(in)	(mm)	(in)	(mm)	(lbs)	(kg)	(lbs)	(kg)	(lbs)	(kg)
16" DN400	150 - 600	sch 120 (4)	HL2Z-16P120	13.06	331.7	13.06	331.7	2	8	1-5/8	12-3/4	323.9	25-3/4	654.1	5-3/4	146.1	397	179.9	528	239.2	725	328.5
		sch 100	HL2Z-16P100			13.44	341.4								5-3/4	146.1						
		sch 80	HL2Z-16P80			13.81	350.8								5-3/4	146.1						
		sch 60	HL2Z-16P60			14.19	360.4								5-3/4	146.1						
		sch 40/xs	HL2Z-16P40			14.50	368.3								5-3/4	146.1						
		sch 30/std	HL2Z-16PSTD			14.75	374.7								5-3/4	146.1						
		sch 20	HL2Z-16P20			14.88	378.0								5-3/4	146.1						
18" DN450	150 - 600	sch 120 (4)	HL2Z-18P120	14.75	374.7	14.75	374.7	2	10	1-5/8	12-3/4	323.9	26	660.4	6-1/2	165.1	497	225.2	656	297.2	890	403.3
		sch 100	HL2Z-18P100			15.19	385.8								6-1/2	165.1						
		sch 80	HL2Z-18P80			15.62	396.7								6-1/2	165.1						
		sch 60	HL2Z-18P60			16.00	406.4								6-1/2	165.1						
		sch 40	HL2Z-18P40			16.38	416.1								6-1/2	165.1						
		xs	HL2Z-18PXS			16.50	419.1								6-1/2	165.1						
		sch 30	HL2Z-18P30			16.62	422.1								6-1/2	165.1						
		std	HL2Z-18PSTD			16.75	425.5								6-1/2	165.1						
		sch 20	HL2Z-18P20			16.88	428.8								6-1/2	165.1						
20" DN500	150 - 600	sch 100 (4)	HL2Z-20P100	16.94	430.3	16.94	430.3	2	12	1-5/8	12-3/4	323.9	28-1/2	723.9	6-1/2	165.1	640	290.0	870	394.2	1200	543.7
		sch 80	HL2Z-20P80			17.44	443.0								6-1/2	165.1						
		sch 60	HL2Z-20P60			17.88	454.2								6-1/2	165.1						
		sch 40	HL2Z-20P40			18.31	465.1								6-1/2	165.1						
		sch 30/xs	HL2Z-20PXS			18.50	469.9								6-1/2	165.1						
		sch 20/std	HL2Z-20PSTD			18.75	476.3								6-1/2	165.1						
		sch 10/10s/5	HL2Z-20P10			19.06	484.1								6-1/2	165.1						
24" DN600	150 - 600	sch 120 (4)	HL2Z-24P120	19.88	505.0	19.88	505.0	2	12	1-5/8	12-3/4	323.9	28-1/2	723.90	6-1/2	165.1	932	422.3	1255	568.6	1750	792.9
		sch 100	HL2Z-24P100			20.44	519.2								6-1/2	165.1						

(1) Standard Seal Material = Urethane

(3) Seal to pipe clearance is approximately 1/2", clearance may be slightly smaller on plugs that accommodate more than one schedule size.

(2) Standard Operating Pressure:

Questions? Contact EST Group Customer Service at any of the following locations.



EST Group  
[www.cw-estgroup.com](http://www.cw-estgroup.com)

**North, Central & South America**

EST Group Corporate Office  
 2701 Township Line Road  
 Hatfield, PA 19440-1770 USA  
 P: +1.215.721.1100  
 +1.800.355.7044  
 F: +1.215.721.1101  
[est-info@curtisswright.com](mailto:est-info@curtisswright.com)

**Europe / Middle East / Africa**

EST Group B.V.  
 Hoorn 312a  
 2404 HL Alphen aan den Rijn  
 The Netherlands  
 P: +31.172.418841  
 F: +31.172.418849  
[est-emea@curtisswright.com](mailto:est-emea@curtisswright.com)

**China**

P +86.400.636.5077  
[est-china@curtisswright.cn](mailto:est-china@curtisswright.cn)

**Singapore**

P +65.3158.5052  
[est-asia@curtisswright.com](mailto:est-asia@curtisswright.com)