



Pop-A-Plug® II (P2) NEAR END PLUGGING PROCEDURE

WARNING

- The user must read and thoroughly understand these installation instructions before any work begins. The user should also watch the P2 Installation & Training Video to learn how to handle and properly use the equipment. It is the responsibility of the user to establish appropriate safety, health and training measures for their personnel using, servicing or working in an area where this equipment is being used.
- The user must be a qualified operator familiar with correct operation, maintenance and use of hydraulic tools. Lack of knowledge in any of these areas can lead to personal injury.
- Trapped pressure in plugged or sealed tubes may cause tapered tube plugs or other plug types to be explosively ejected from the tube during maintenance work. Protective shielding or similar equipment must be in-place to protect users and others working in the area of the heat exchanger.



- Wear proper eye protection to protect against ejected parts or other projectiles. A face shield is recommended.
- Wear proper ear protection to protect against hearing loss or damage.
- Although vibration of the hydraulic ram is minimal during operation, work gloves are recommended to protect hands during operation.
- Possible Kickback and Parts Ejection Hazard. Keep body, head, face and all extremities clear from rear of hydraulic ram during operation.
- Tools and components listed in this instruction are designed for the sole

purpose of installing P2 heat exchanger tube plugs. The equipment is not designed or intended to be used for other tasks.

- Power tools are not generally suited for coming in contact with electrical power sources.
- Power tools shall not be used in an explosive atmosphere unless specifically designed for that purpose.
- Unexpected tool movement or breakage of inserted tool could cause injury to personnel.
- Unsuitable postures may not allow for proper counteracting of normal or unexpected movement of the tool during operation.
- Inspect equipment before each use to prevent unsafe conditions from developing. Do not use equipment if it is damaged, altered or in poor condition.
- These instructions are intended for the end-user or operator of this equipment. For additional information or parts lists contact an EST Group facility listed below.

Pictogram Definitions



READ INSTRUCTIONS
Read all instructions before initiating work.



EYE PROTECTION
Wear proper eye protection to protect against ejected parts or projectiles. A face shield is recommended.



EAR PROTECTION
Wear proper ear protection to protect against hearing loss or damage.



PUMP
Activating the pump with the pedal end marked with this pictogram, the flow of fluid is directed out of the reservoir.



RELEASE
Activating the pump with the pedal end marked with this pictogram, the flow of fluid is directed back to the reservoir.

**CURTISS-
WRIGHT**
EST Group
<http://estgroup.cwfc.com>

North America / Central & South America
EST Group Corporate Office
2701 Township Line Rd
Hatfield, PA 19440-1770 USA
(P) +1.215.721.1100
+1.800.355.7044
(F) +1.215.721.1101
est-info@curtisswright.com

Europe / Middle East / Africa
EST Group B.V.
Hoor 312a
2404 HL, Alphen aan den Rijn
The Netherlands
(P) +31.172.418841
(F) +31.172.418849
est-emea@curtisswright.com

Asia Pacific
EST Group Asia
35 Tannery Rd, #11-10 Tannery Block
Ruby Industrial Complex
Singapore 347740
(P) +65.6745.8560
(F) +65.6742.8700
est-asia@curtisswright.com

China
EST Group China
Rm 3709, China World Office 1
No.1 Jian Guo Men Wai Avenue
Beijing, 100004
(P) +86.10.65058966
(F) +86.10.65050966
est-china@curtisswright.cn

HOW THE SYSTEM WORKS

The Near End Plugging Procedure is to be followed for all plugging applications in U-Tube heat exchangers and in straight tube heat exchangers where the operator has access to both ends of the tube. P2 is to be installed only into tubes that have been expanded into the tubesheet by rolling or other methods.

The heat exchanger tube to be plugged must be prepared and gauged for size by following the tube preparation procedures given in this instruction.

The P2 consists of a tapered pin, an internally and externally serrated ring and a breakaway. The plug is threaded onto a Pull Rod Assembly. The assembly is then inserted into the Hydraulic Ram. The plug is then ready to be recessed into the end of the faulty tube to be plugged.

During installation, the tapered pin is pulled through the ring, causing it to expand outward. The ring expands until it makes contact with the ID of the tube. The tube ID restricts the expansion of the ring, causing an increased force on the Breakaway. When the proper installation force is achieved, the Breakaway pops and the installed plug is separated from the installation equipment.

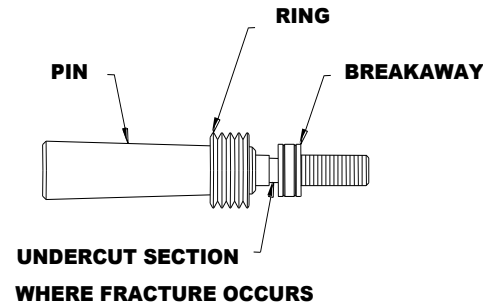

The P2 material must be closely matched to the tube and/or tubesheet material to minimize effects of thermal expansion and galvanic corrosion over the service life of the heat exchanger.

Each plug is stamped with the plug size, in inches, rounded to three decimal places, and a single letter material designation. The plug size corresponds to the actual OD of the ring portion of the plug. The common material designations are as follows:

(S)	316 Stainless Steel	(N)	Copper/Nickel
(B)	Brass	(M)	Monel
(C)	Carbon Steel		

P2 PLUG SIZING

Prior to beginning any tube plugging, it is necessary to determine the size or sizes of P2's that will be required. The procedures given below have been used with success in estimating the proper P2 size(s) for the tubes to be plugged.

The correct sized P2 must fit into the tube and be no more than .020" (.5 mm) smaller than the **actual** tube ID in the position where the plug will be installed. P2's are readily available in .020" (.5 mm) increments from .400" to 2.000" (10.16 mm to 50.8 mm). Sizes from .400" to .960" (10.2 mm TO 24.4 mm) and are generally in stock in each of the (5) standard materials listed above. For larger sizes and alternate materials contact EST

Although these estimating procedures will aid in plug sizing for the majority of applications, occasionally the actual ID's will differ substantially from the calculated value due to tube end erosion or similar effects. If you find that the actual tube ID's differ from the estimated ID's, measurements of the actual tubes must be taken. Taking measurements of the actual tubes is the best method to determine the exact tube ID's. We recommend taking measurements in all cases where it is possible.

1. Tube ID Measurement (if not access to heat exchanger is not possible proceed to Step 2).

Make and record a horizontal and vertical measurement of each tube ID at a depth where the plug will be installed. A snap bore gage or ID micrometer is recommended for these measurements. The plug should be positioned at an installation depth of 1-3/4" (44.5 mm) (minimum as long as the expanded length (e.g. roller expanded) of the tube and tubesheet thickness is greater than 1-3/4" (44.5 mm). If the expanded length of tube or tubesheet thickness is less than 1-3/4" (44.5 mm) the installation depth for the plug needs to be reduced accordingly.

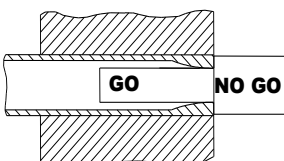

Alternate Go/No-Go Gauging: Contact EST for a Go/No-Go Gage to aid in determining the correct P2 size. The use of the Go/No-Go Gage will require that any weld droop protruding into the tube ID is removed.

Heat Exchangers manufactured with a soft roll close to the face of the tubesheet will give a false Go/No-Go gage reading and plugs will be undersized and subject to failure. The soft roll must be brushed out to achieve uniform tube ID and true Go/No-Go gage reading.

2. Calculated Tube ID

Consult the Heat Exchanger Data Sheet supplied by the heat exchanger manufacturer to determine the tube OD and wall thickness. From the data sheet it is also necessary to determine if the tubes have been rolled or expanded by a similar method.

3. P2 Sizing

For rolled or expanded tubes consult Table 1 for the proper P2 sizes.

If the tubes have not been roller expanded or if the heat exchanger has inlet tube shields or coated tube ID's, call EST for assistance in determining the proper method and correct sizes of P2.

NOTE: This sizing procedure is only a starting point! Our experience has shown that the actual ID of the tubes can be significantly larger than estimated. Size variations can be caused by over rolling, corrosion or erosion. Differences as high as .090" (2.3 mm) between the inlet and outlet tube ID's are occasionally encountered.

If the tubes cannot be measured prior to ordering P2's, it is recommended that in addition to the recommended P2 size, the next larger consecutive size be ordered to have on hand. Unused sizes between P2-400 and P2-960 in our 5 stock materials can be returned or exchanged if they are unopened.

Tube Sizing Example

Select the correct P2 for a 3/4" (19.1 mm) x 12 B.W.G. rolled tube. According to Table 1, the ID of the rolled tube is .554" (14.1 mm). The chart specifies a P2-540. However, allowing for possible tube end erosion and/or over rolling, the actual tube ID may be closer to .560" (14.2 mm). Knowing that brushing the tube ID with the tube preparation brush will enlarge the tube ID, it is recommended that P2-560 also be on hand.

4. Equipment Required

In addition to the proper size and material of P2's, it is important that the proper installation equipment also be on hand. Existing obstructions such as channel heads and hemispherical heads can limit accessibility to perimeter tubes. The use of installation equipment designed for these conditions is the only way to ensure proper installation of the P2.

Below is a list showing the minimum equipment that should be on hand prior to beginning any plugging. Refer to Tables 1 & 2 for part numbers of listed equipment.

1. P2 kits of proper size(s)
Kit includes:
 - (10) P2 tube plugs
 - (1) Tube preparation brush.
 - (1) Go/No-Go Gage to verify plug sizing
2. Hydraulic Ram with safety cable for installation
3. (1) Pull Rod Assembly (Standard or Channel Head as required).
The pull rod assemblies are matched to the size of the P2's.
4. (1) Spare Plug Positioner.
5. Electric or air powered drill, for tube brushing.
6. For rolled and welded tubes, a tapered reamer to remove weld droop

For Perimeter Tubes

Frequently the tubes that require plugging are on the perimeter of the tubesheet. Hemispherical heads often present clearance problems making it difficult or impossible to use the standard Ram. For these applications, EST can supply a special Close Quarters Ram, Model CQR-1000. Contact EST for additional information.

5. Technical Assistance

If any part of the plug sizing procedure or equipment required is not clear, please contact EST with the following information:

- Tube size and Wall Thickness
- Operating Pressure and Temperature
- Tube and Tubesheet Material
- Tube Joint Type (Rolled/Welded)
- Existing Obstructions (Channel Head, etc.).

TUBE PREPARATION AND SIZE VERIFICATION

6. Remove weld droop

If tube is welded to sheet, remove weld droop with a **TAPERED REAMER**.

Removing weld droop is a fairly quick step and should only take 15-30 seconds. Only remove the weld (burr) projecting into the tube ID. Use a tapered reamer not a straight reamer. Size the reamer so that the small end of the taper fits into the tube and the large end does not.

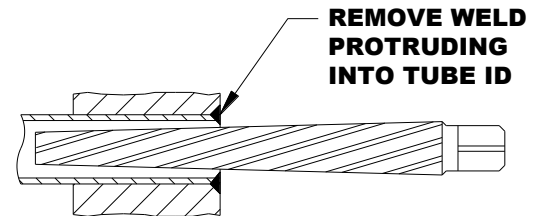

The reamer should be operated in the following manner:

- Install tapered reamer in a variable speed drill and lightly lubricate reamer with cutting oil.
- Keep reamer axis parallel to tube axis.
- Use an on/off method. Lightly squeeze the trigger on the drill to a low rpm and then release.
- Use very slight forward pressure when pushing the reamer into the tube end. Too much pressure may cause the reamer to catch.
- Let the reamer do the work. Never force the reamer into the tube end.



WARNING

Failure to remove weld droop will cause Go/No Go gage to give a false reading. This false Go/ No Go gage reading will direct user to install an **UNDERSIZED PLUG** which will leak either initially or later.

7. Gage tube size using Go/No-Go Gage

Insert the Go end of the Go/No-Go Gage supplied in the P2 kit into the tube end. Attempt to insert the Go end of the gage into the tube to the depth the plug will be installed. (1-3/4" (44.5 mm) is recommended as long as expanded length (e.g. roller expanded) of the tube and tubesheet thickness is greater than 1-3/4" (44.5 mm). If the expanded length of tube or tubesheet thickness is less than 1-3/4" (44.5 mm), the installation depth for the plug needs to be reduced accordingly. If the go end of the gage does not fit, the P2 size chosen is too large. Go to a smaller size and repeat this step.

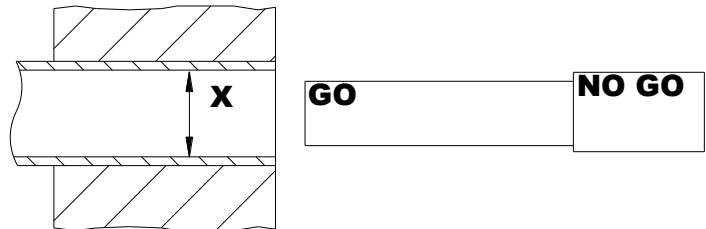

If the Go end of the gage fits, remove the gage from the tube end and attempt to insert the No-Go end of the gage into the tube.

If the No-Go end fits, the P2 size chosen is too small. Go to a larger size and return to the beginning of step 6. If the Go end of the gage fits into the tube, to the installation depth and the No-Go end does not fit, the P2 size chosen is the correct size for this tube. The gage size, which corresponds to the P2 size, is stamped on the end of each gage. Make certain that the tube brush and P2 that are going to be used are marked with the same size that is marked on the correct Go/No-Go Gage.

8. Prepare ID using Tube Preparation Brush

Before attempting to plug any tube, the tubes must be cleaned to a depth beyond the established plug installation depth. Scale, pitting or corrosion on the inside wall of the tube could interfere with the sealing capability of the plug and must be removed prior to plugging. Use of the brush will also aid in the performance of the plug.

A tube preparation brush corresponding to P2 size is provided with each P2 kit. It is designed to clean and roughen the tube ID in the position where the P2 will be installed. The size of the brush that corresponds to the P2 size is stamped on the shank of the brush. Make certain the

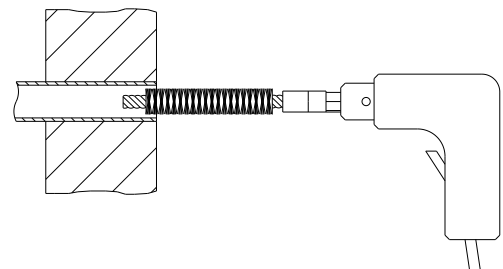

brush to be used is marked with the same size as the Go/No-Go Gage used in step 7.

Attach the tube preparation brush to an electric or air powered drill that is capable of approximately 300 to 500 RPM. Use the tube brush marked with the same size as the Go/No Go gage that fits after removing weld droop. Operate the brush with a power drill for at least 30 seconds (5 seconds for 90/10 Cu/Ni and Brass tubes) back and forth from the tube opening to the installation depth evenly to prevent a tapered condition. If as a result of uneven brushing the tube entrance is smaller, the installed plug may be undersized and leak. Do not use an oversized brush, force the brush into the tube, or bend the stem. These actions will break the stem and cause deep grooves in the tube. Do not reverse drill because bristles will fall out. A Brush lubricant / Spark inhibitor Lube-A-Tube is available from EST, if required. Lube-A-Tube should be used when brushing stainless steel tubes or brush may wear out quickly.

NOTE: Each P2 kit includes a tube preparation brush. After 10 tubes have been prepared discard the brush and obtain a fresh brush. Brush using clockwise motion only or brush may lose bristles.

9. Inspect tube ID for defects

Remove any loose particle or material from the tube ID and carefully inspect tube for scale, pitting or other defects. These conditions must be corrected for plug to seal properly. A properly brushed tube should have a shiny metallic finish. Deeply pitted tubes may require the use of larger preparation brushes and plugs.

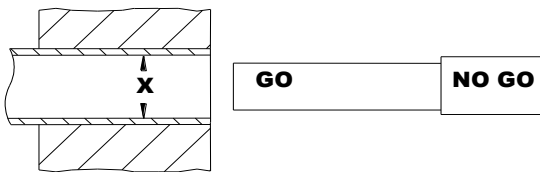

10. Re-gauge tube ID to verify correct size

Since material is removed from the tube ID during brushing, the tube ID must be re-gauged using the correctly sized Go/No-Go Gage used previously. As in step 7, the Go end of the gage should fit to the installation depth and the No-Go should not.

If the No-Go end now fits into the tube to the installation depth it is necessary to go to the next larger P2 size and repeat this step.

**IF TUBESHEET THICKNESS ALLOWS.
INSTALLATION DEPTH = 1-3/4" MIN**

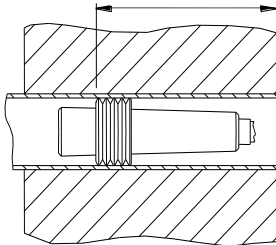

11. Repeat steps 6-10 for each tube to be plugged

Although each tube in a Heat Exchanger is theoretically the same size, the actual tube ID's may vary. When installing more than one P2, repeat the preparation and sizing steps for each tube.

12. Proceed to hydraulic installation

After each tube has been properly prepared and the correct P2 size has been determined, the tubes are ready to be plugged.

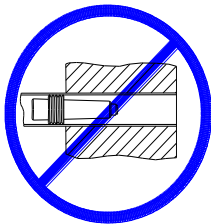

HYDRAULIC INSTALLATION



WARNING

The P2 must be installed into the tubesheet area of the tube only. The installed plug should never project beyond the tubesheet face unless it is on the perimeter, in a thin tubesheet or the roll length is insufficient. If the tubesheet is not thick enough or the roll length is insufficient to allow an installation depth of 1 3/4" (44.5 mm), the installation depth must be reduced accordingly.



WARNING

**NEVER HIT THE PIN WITH A HAMMER OR HEAVY OBJECT.
P2's MUST NOT BE USED IN ANY HEATER IF THE TUBE IS NOT EXPANDED TO THE
TUBESHEET.**



WARNING

Hydraulic Pump and Hydraulic Ram

User must read and thoroughly understand the detailed instructions, safety precautions, inspection prior to operation, maintenance and troubleshooting for the hydraulic pump and hydraulic ram. Refer to the supplied documents listed below:

Hydraulic Pump (Model PA-6) refer to form no. 105001

Hydraulic Ram refer to form no. 102397

EST supplies the Hydraulic Pump, Hydraulic Ram, Hydraulic hose and other hardware as part of a kit. The part number and description of each kit is listed here:

Part Number	Description
PAP-6600	Small Ram Package for installing P2-400 to P2-1160 sizes. Includes hydraulic pump, hose and a white hydraulic ram approximately 4-1/8" (104.8 mm) long.
PAP-1750	Large Ram Package for installing P2-1180 to P2-2000 sizes. Included hydraulic pump, hose and orange, twin cylinder, hydraulic ram. Ram can be identified by (4) external retraction springs.



DANGER

Using a Hydraulic Pump or Hydraulic Ram that has not been inspected and maintained in accordance with the instructions could result in a dangerous situation, serious injury or death.

13. Venting the Oil Reservoir

Remove the shipping plug from the oil fill port on the hydraulic pump and install the vent cap before using the pump.

14. Check pump oil level

Check the fluid level in the Hydraulic Pump. The fluid level should be approximately 1/2" (12.7 mm) from the vent cap when the pump is in the release position. If necessary fill with clean hydraulic oil; ASTM Grade 215, ISO Grade 46 or equivalent.

15. Connect hose to Pump and Ram

Connect the Hydraulic Hose between the Ram and the Hydraulic Pump. Make certain that both connections are seated and fully threaded together.

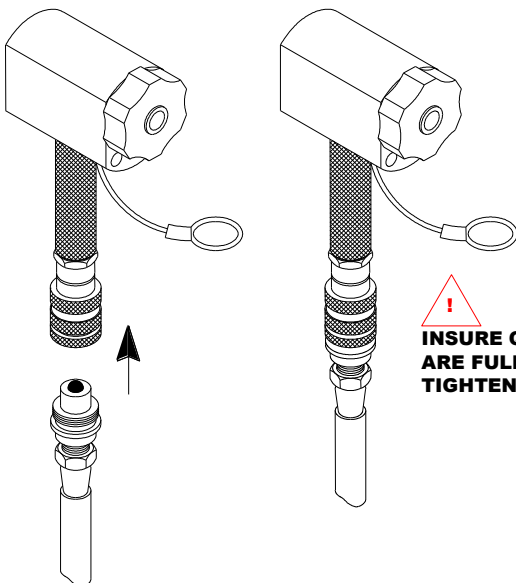

**INSURE QUICK CONNECTS
ARE FULLY ENGAGED AND
TIGHTENED**



WARNING

Insure hydraulic hose quick connects are fully engaged and tightened. Failure to correctly seat and tighten hydraulic fittings will cause ram piston to lock in extended position after activation. See Troubleshooting.

16. Connect air supply

Remove the thread protector from the air inlet of the pump. Select and install the threaded fittings that are compatible with your air supply fittings. An in-line filter/lubricator should be installed close to the pump. Add a few drops of hydraulic oil, ASTM Grade 215, ISO Grade 46 or equivalent, to air intake weekly if no lubricator is used or when pump will be idle for a long time. A clean, dry and lightly lubricated air supply will insure long pump life. The air supply should be 20 CFM (.57M³/min.) and approximately 100 psi (7 Bar) at the pump. Air pressure should be regulated to a maximum of 140 psi (9 Bar). Connect the air supply fitting to the Hydraulic Pump.

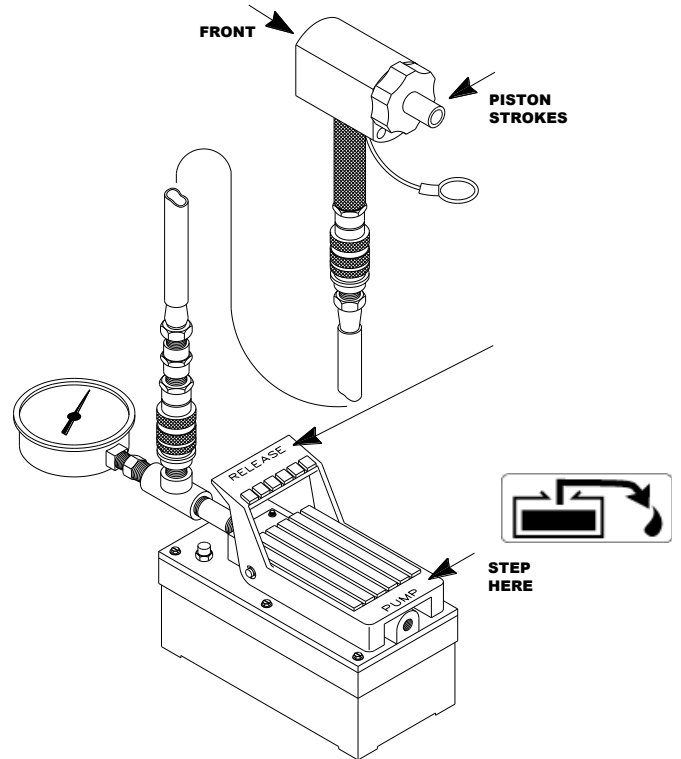
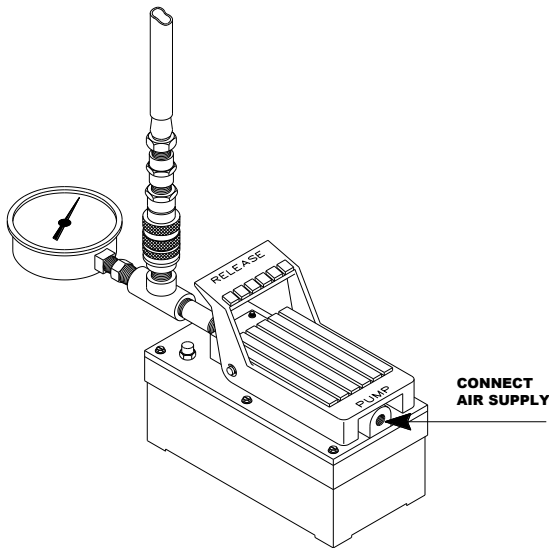

17. Test Ram/Pump set-up

To verify Ram/Pump set-up, step on the end of the pump pedal marked "PUMP"  while watching the Hydraulic Ram. Within a few seconds, the Ram should begin to stroke. Note that the piston strokes out of the back of the hydraulic Ram. If the Ram does not stroke, check all connections, the oil level and repeat this step.

18. Obtain Pull Rod Assembly

Based on the plug size being installed, obtain the appropriate Pull Rod Assembly.

NOTE: The Standard Pull Rod Assembly consists of the following:

- a. Pull Rod -female thread in one end, male thread on the other end.
- b. Plug Positioner.
- c. Rod & Tube Positioner.
- d. Knurled Nut which threads on to the male end of the Pull Rod after it is inserted into the Ram.

The Channel Head Pull Rod consists of the above parts and:

- e. Stand-off ring.
- f. Compression Tube which fits over the Pull Rod.

19. Check Pull Rod Assembly Verify that the Pull Rod Assembly is assembled correctly. The directional arrows stamped on both the Rod and Tube Positioner and the Plug Positioner should always point towards the end of the Pull Rod where the plug will be attached.

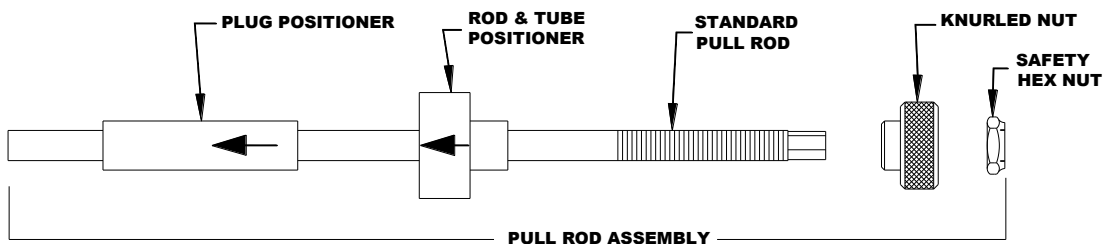

Note: The Rod and Tube Positioner for P2-880 and larger plug sizes is a flat washer. It is not stamped with an arrow and may be installed in either direction.

20. Adjust Stand-off Ring (Channel Head Pull Rod only)

If using a Channel Head Pull Rod Assembly, adjust the Stand-off Ring to allow each plug to be installed at the desired installation depth.

NOTE: The P2 must be installed into the expanded portion of the tube end within the tubesheet only. The installed plug should **never** project beyond the tubesheet face unless it is on the perimeter, in a thin tubesheet or the roll length is insufficient. If the tubesheet is not thick enough or the roll length is insufficient to allow an installation depth of 1 3/4" (44.5 mm), the installation depth must be reduced accordingly.

21. Select P2

P2's are shipped 10 to a box and sealed in individual packing tubes to prevent damage. Carbon steel plugs are also packed with a rust preventative strip.



WARNING

NEVER ATTEMPT TO INSTALL A DAMAGED OR RUSTED PLUG.

Select the P2 size corresponding to the correct size Go/No-Go Gage used previously. Visually inspect the plug to make certain that no damage was caused during handling. The ring portion should be free of scars or dents across the serrations. The finish of the pin should be clean and smooth.



WARNING

IF THE P2 APPEARS DAMAGED, DISCARD IT! NEVER ATTEMPT TO INSTALL A DAMAGED OR RUSTED PLUG.



WARNING

THE UNDERCUT SIDE OF THE BREAKAWAY IS ALWAYS INSTALLED TOWARD THE PIN. THE BREAKAWAY IS TIGHTENED INTO THE PIN AT THE FACTORY TO PREVENT LOOSENING OR REMOVAL. PRIOR TO INSTALLATION NEVER ATTEMPT TO REMOVE THE BREAKAWAY FROM THE PIN.



DANGER

IF THE BREAKAWAY IS INTALLED BACKWARDS THE PULL ROD COULD BE EJECTED FROM THE HYDRAULIC RAM DURING PLUG INSTALLATION

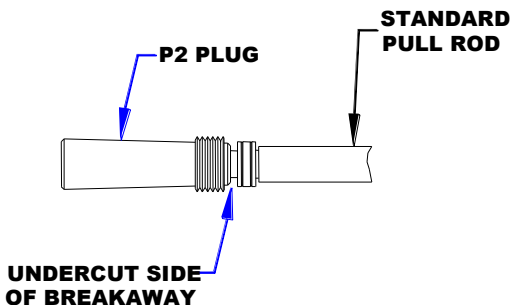

22. Thread plug into Pull Rod

Thread the P2 into the end of the Pull Rod Assembly. Make certain that the Breakaway thread is fully engaged into the Pull Rod Assembly or stripping of the threads may occur.

23. Insert Pull Rod into Ram

Remove the safety hex nut and Knurled Nut and insert the male threaded end of the Pull Rod Assembly with Pop-A-Plug attached through the front of the Ram. Note that when the pump is activated the ram strokes out of the rear end of the ram.

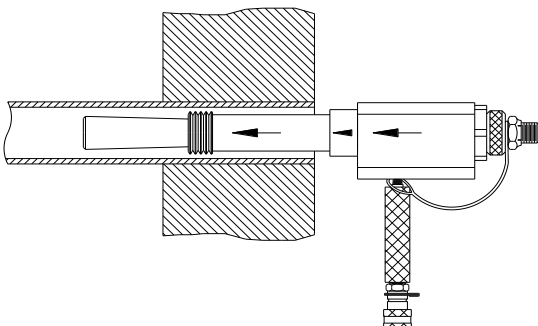

NOTE: Current Rams are stamped with a directional arrow. This arrow points toward the front of the Ram. Also this arrow should point

towards the P2 as do both arrows on the Rod & Tube and Plug Positioner.

24. Install Knurled Nut onto Pull Rod

Thread the Knurled Nut onto the Pull Rod until it is tight against the large black nut on the back of the Hydraulic Ram.

NOTE: The Knurled Nut used for P2-400 to P2-860 is stepped. The smaller diameter step should be installed towards the ram. The step fits into the piston ID and centers the pull rod. The Knurled Nut used on larger P2 sizes is flat and can be installed in either direction.

After hand tightening the Knurled Nut there should be no "play" between the parts of the assembled Pull Rod. The Plug Positioner should be tight against the ring of the P2. The OD of the Plug Positioner should fit against the end surface of the ring. If the Plug Positioner OD is larger than the ring or the Positioner end does not fit against the end surface of the ring, the Plug Positioner selected is not the correct size or is installed backwards. Refer to Table 1 for part numbers. Obtain the correct parts and repeat this step.

25. Install Safety Cable

Slip loop in Safety Cable over exposed threaded end of Pull Rod so it rests against the Knurled Nut. While holding the safety Cable in place thread the Safety Hex Nut onto the Pull Rod hand-tight.

**IF TUBESHEET THICKNESS ALLOWS.
INSTALLATION DEPTH = 1-3/4" MIN**

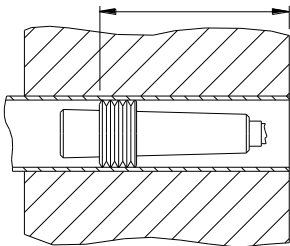

Recess P2 into tube

While holding the ram, insert the P2 into the tube and recess it to the installation depth. P2's must always be installed into the portion of the tube restrained by the tubesheet.

NOTE: The desired installation depth is 1 3/4" (44.5 mm). This depth will prevent the pin of the P2 from projecting beyond the face of the tubesheet after the plug is installed. If the thickness of the tubesheet or the expanded length of the tube does not permit a 1-3/4" (44.5 mm) installation depth, install the plug as deep as possible while keeping the plug positioned within the tubesheet.

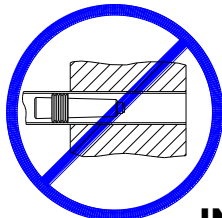

**INSTALLATION
DEPTH
1-3/4" MIN**

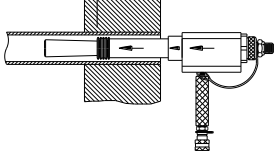

DANGER

**POSSIBLE KICKBACK AND PARTS
EJECTION HAZARD. KEEP BODY AND
ALL EXTREMITIES CLEAR FROM REAR OF
HYDRAULIC RAM DURING OPERATION.**



**MAKE
CERTAIN
SAFETY
CABLE IS
ENGAGED**

**WITH PULL ROD ASSEMBLY
PRIOR TO OPERATION.**

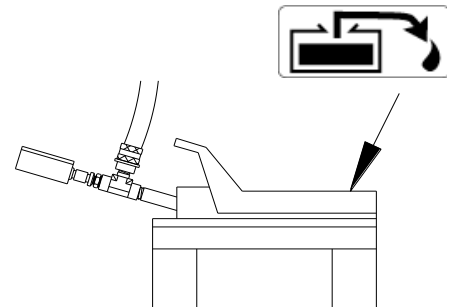

WARNING

**NEVER OPERATE THE HYDRAULIC RAM IF THE P2
PLUG IS NOT WITHIN THE HEAT EXCHANGER
TUBE.**

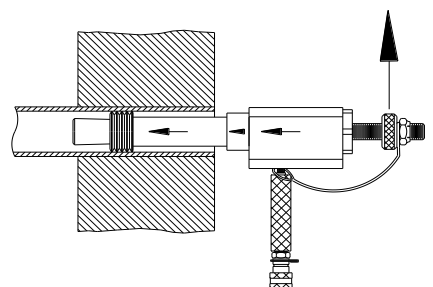

26. Activate Ram to install plug



While guiding the Ram with hands to avoid cocking of the P2 plug, activate the Hydraulic Pump by stepping on the end of the pedal marked "PUMP".  Pressure will start to build within the ram and the piston will begin to stroke. Continue to operate the pump until the Pop-A-Plug "Pops" or the Ram is fully stroked and the pressure gauge on the pump reaches approximately 7500 psi (515 Bar).

**WARNING**

IF AFTER ONE FULL STROKE OF THE RAM, THE P2 PLUG HAS NOT CONTACTED THE TUBE ID, THE P2 SIZE IS TOO SMALL. REMOVE THE PLUG AND REPEAT THE SIZING PROCEDURE.

NOTE: The Hydraulic Ram used in the PAP-6600 Ram Package has a maximum stroke of 1" (25.4 mm). When the piston in the Ram reaches the maximum stroke, the pressure shown on the gauge will dramatically increase.

If P2 plug contacted the tube ID but the plug did not "POP", a second stroke of the Hydraulic Ram is necessary. For the second stroke of the Hydraulic Ram:

- A. Continue to support the weight of the Ram.
- B. Step on the end of the Hydraulic Pump marked "RELEASE".  This will cause the piston in the Hydraulic Ram to retract.
- C. Remove slack in the Pull Rod by hand tightening the Knurled Nut. After hand tightening the Knurled Nut there should be no "play" between the parts of the Pull Rod Assembly.
- D. Step on the Pump pedal marked "PUMP"  to re-stroke the Ram.

DANGER

POSSIBLE KICKBACK AND PARTS EJECTION HAZARD. KEEP BODY AND ALL EXTREMITIES CLEAR FROM REAR OF HYDRAULIC RAM DURING OPERATION. MAKE CERTAIN SAFETY CABLE IS ENGAGED WITH PULL ROD ASSEMBLY PRIOR TO OPERATION.



NOTE: If the P2 does not "POP" on the second stroke of the Ram, or if the pressure gauge on the pump reaches approximately 7500 psi (515 Bar) before the plug "POPS", or if the breakaway fractures on the side opposite the undercut **STOP! THE PLUG IS TOO SMALL. THE PLUG MUST BE REMOVED EVEN IF IT PASSES AN AIR OR HYDRO TEST!** Unthread the Pull Rod Assembly and Remove the plug using EST's Plug Removal Tool. Repeat tube sizing and preparation procedure prior to installing new plug.

27. Plug is installed

When the P2 has been installed, the Breakaway will fracture and the Pull Rod and Hydraulic Ram assembly will be separated from the installed plug. Remove the breakaway stub after plug installation.

**WARNING**

Care must be exercised not to hit or force the installed plug when removing the breakaway stub.

28. Release Pump pressure

While holding the Ram handle step on end of the Pump Pedal marked "RELEASE".  This will allow the piston of the Ram to retract.

29. Remove Knurled Nut

Remove the Knurled Nut from the back of the Pull Rod.

30. Remove broken Breakaway section from Pull Rod

If installing additional plugs, remove the Breakaway section remaining in the Pull Rod end and discard. If no further plugs are being installed leave the broken Breakaway section in the pull rod. This will keep the Pull Rod Assembly together.

31. Repeat steps 19-32

Repeat Steps 19 through 32 for the remaining tubes to be plugged.

WHEN PLUGGING IS COMPLETED**32. Pressure Testing of Installed Plug**

After plug installation is complete it is common practice to perform a pressure test of the installed plug by introducing air or water to the shell side of the heat exchanger. Installed plugs can be evaluated for leak-tightness while under-pressure. Foaming or bubbling leak detectors will aid in evaluating plugs under air test.

**WARNING**

- **Extreme caution is necessary when performing a pressure test. It is the responsibility of the user to establish appropriate safety, health and training measures for their personnel performing or working in an area where a pressure test is being conducted.**
- **Never stand in the potential path of an installed tube plug**
- **Never attempt to force or adjust an installed tube plug.**

NOTE: Small leakage or weeping during pressure test indicates small surface imperfections in the tube that are difficult to see. A large leak indicates surface imperfection in the tube such as scarring from a drill used to remove a sleeve or tapered pin, that should have been seen in step 9. In either case, remove plug using EST removal tool and repeat procedure using next larger brush and plug size.

33. Replace knurled nut

Replace the Knurled Nut on the threaded end of the Pull Rod.

34. Return Pull Rod to Tool Box

Return the Pull Rod Assembly to its place in the toolbox, or to an appropriate storage location.

35. Return Ram to Tool Box

Disassemble the Ram and return it to the toolbox.

36. Return unused P2's to box

If any unused P2's have been removed from their storage tubes, return them to their storage tubes and then into the proper P2 box.

SHORT FORM INSTALLATION INSTRUCTIONS, DC4010

Included with each P2 kit is a one-page short form instruction sheet. The first side describes the installation procedure in pictorial form. The second side describes the part numbers for P2 and the appropriate installation Pull Rods. It is recommended that this sheet be kept with the plugs and be reviewed prior to any tube plugging.

DEMONSTRATION/TRAINING VIDEO, DC4018

Included in each new Hydraulic Ram Package is a demonstration/training video of the P2 tube plugging procedures. This video is also available for your training library by contacting EST, or your EST Representative or distributor.

TO RETURN ANY MATERIAL

If it should become necessary to return any material, for any reason, contact EST for a RETURN MATERIAL AUTHORIZATION NUMBER (RMA #). Material returned without an RMA # will delay corrective action, credits or returned shipments. Complete unused/unopened P2 kits from P2-400 to P2-960 in our 5 stock materials in quantities less than our normal inventory level may normally be returned. Returned materials may be subject to a restocking fee.

QUESTIONS?

Contact EST Group Customer Service at any of the following locations with questions.

- In USA and Canada: tel: 800-355-7044, 215-721-1100; e-mail: est-info@curtisswright.com
- In Europe: tel: +31-172-418841; e-mail: est-emea@curtisswright.com
- In Asia: tel: +65-6745-8560; e-mail: est-asia@curtisswright.com
- In China: tel: +86-10-65058966; e-mail: est-china@curtisswright.cn
- On the Internet: <http://estgroup.cwfc.com>

EST Group provides a complete range of repair products, services, and replacement parts covering the life cycle of heat exchangers and condensers; additionally EST Group provides products and services to facilitate pressure testing pipe, piping systems, pressure vessels, and their components. Visit EST Group on the Internet at <http://estgroup.cwfc.com>.

Operator Troubleshooting Guide

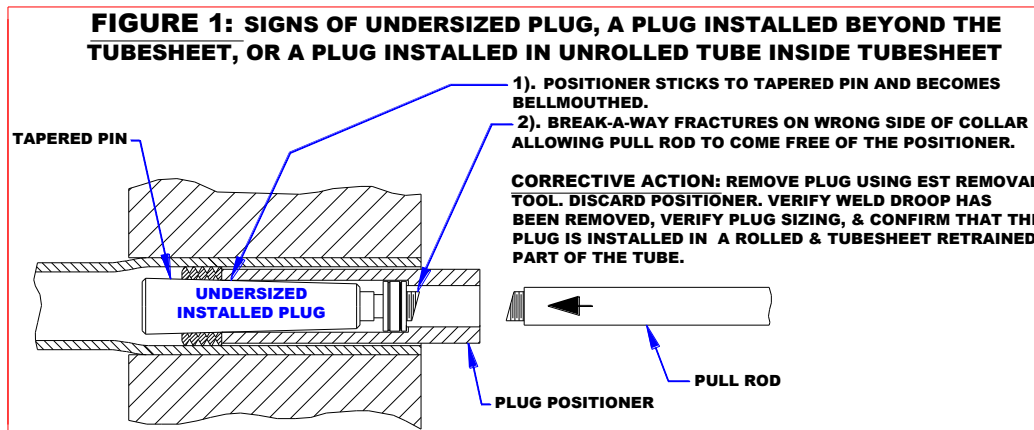

Problem	Cause	Solution
<ul style="list-style-type: none"> Imperfections such as pitting, gouges or scratches still exist within the tube ID after brushing. 	<ol style="list-style-type: none"> Deep imperfections can exist for normal heat exchanger operation or maintenance work. 	<ol style="list-style-type: none"> Continue brushing with tube preparation brush until little or no resistance is encountered. If imperfections still exist move up to the next P2 kit size and repeat tube preparation steps.
<ul style="list-style-type: none"> Plug Positioner flares or becomes stuck on installed P2 plug. Breakaway fractures on side opposite the undercut. (Normally the Breakaway fractures at the undercut) P2 Plug does not "POP" after second stroke of hydraulic ram. 	<ol style="list-style-type: none"> Undersized Plug (Refer to Figure 1) The plug was installed beyond the thickness of the tubesheet Heat Exchanger tube is not expanded (rolled or similar) into the tubesheet. 	<ol style="list-style-type: none"> Gage or measure tube ID at location where plug will be installed. Refer to Table 1 for proper P2 sizing. Refer to heat exchanger datasheet to determine tubesheet thickness. Install P2 plug within the tubesheet length. Roller expand heat exchanger tube at plug installation depth otherwise contact EST for assistance.
<ul style="list-style-type: none"> Go/No-Go Gage indicates proper P2 size, but problems related to an undersized plug occur. 	<ol style="list-style-type: none"> Weld droop has not been removed. Heat exchanger tube is only "soft rolled" for a short distance and expanded additionally beyond the "soft roll" length. 	<ol style="list-style-type: none"> Remove weld droop using tapered reamer. Using tube preparation brush, enlarge tube so that entrance and "soft roll" area has same ID as at the plug installation depth.
<ul style="list-style-type: none"> Hydraulic Ram is stuck in extended position and will not retract. 	<ol style="list-style-type: none"> Mating quick connects between Ram and hose or between Hydraulic pump and hose are not fully engaged and tightened. Piston within hydraulic ram has been damaged 	<ol style="list-style-type: none"> Using gripping pliers turn locking collar on female quick connect to further engage connection. Continue tightening until ram retracts. Return ram to EST for repair.
<ul style="list-style-type: none"> Stem of Tube Preparation Brush fractures 	<ol style="list-style-type: none"> Brush size is too large The brush was forced or advanced to quickly 	<ol style="list-style-type: none"> Gage tube using Go/No-Go gage and select corresponding brush size. Slowly feed the brush into the tube if significant resistance is encountered.
<ul style="list-style-type: none"> Bristles fall out of Tube Preparation Brush 	<ol style="list-style-type: none"> The brush was run counter-clockwise in the drill. 	<ol style="list-style-type: none"> Obtain a new brush and operate brush clockwise.
<ul style="list-style-type: none"> Inadequate space to get plug into tube when using the standard hydraulic ram with pull rod assembly. 		<ol style="list-style-type: none"> Use EST's Close Quarter Ram for P2 installation.

TABLE 1 Tube ID and P2 Size for Expanded (Rolled or similar) Heat Exchanger Tubes

WALL THICKNESS BWG	DECIMAL		TUBE OD				
			1/2" (12.7 mm)	5/8" (15.88 mm)	3/4" (19.05 mm)	7/8" (22.23 mm)	1" (25.40 mm)
8	.165" (4.19 mm)	ID			.453" (11.51 mm)	.578 (14.68 mm)	.703 (17.86 mm)
		PLUG			P2-440	P2-580	P2-700
9	.148 (3.76 mm)	ID			.484 (12.29 mm)	.609 (15.47 mm)	.734 (18.64 mm)
		PLUG			P2-480	P2-600	P2-720
10	.134 (3.40 mm)	ID			.509 (12.93 mm)	.634 (16.10 mm)	.759 (19.28 mm)
		PLUG			P2-500	P2-620	P2-760
11	.120 (3.05 mm)	ID		.409 (10.39 mm)	.534 (13.56 mm)	.659 (16.74 mm)	.784 (19.91 mm)
		PLUG		P2-400	P2-520	P2-660	P2-780
12	.109 (2.77 mm)	ID		.429 (10.90 mm)	.554 (14.07 mm)	.679 (17.25 mm)	.804 (20.42 mm)
		PLUG		P2-420	P2-540	P2-680	P2-800
13	.095 (2.41 mm)	ID		.454 (11.53 mm)	.579 (14.71 mm)	.704 (17.88 mm)	.829 (21.06 mm)
		PLUG		P2-440	P2-580	P2-700	P2-820
14	.083 (2.11 mm)	ID		.476 (12.09 mm)	.601 (15.27 mm)	.726 (18.44 mm)	.851 (21.62 mm)
		PLUG		P2-480	P2-600	P2-720	P2-840
15	.072 (1.83 mm)	ID		.495 (12.57 mm)	.620 (15.75 mm)	.745 (18.92 mm)	.870 (22.10 mm)
		PLUG		P2-500	P2-620	P2-740	P2-860
16	.065 (1.65 mm)	ID		.508 (12.90 mm)	.633 (16.08 mm)	.758 (19.25 mm)	.883 (22.43 mm)
		PLUG		P2-500	P2-620	P2-760	P2-880
17	.058 (1.47 mm)	ID		.521 (13.23 mm)	.646 (16.41 mm)	.771 (19.58 mm)	.896 (22.76 mm)
		PLUG		P2-520	P2-640	P2-760	P2-900
18	.049 (1.24 mm)	ID	.412 (10.46 mm)	.537 (13.64 mm)	.662 (16.81 mm)	.787 (19.99 mm)	.912 (23.16 mm)
		PLUG	P2-400	P2-540	P2-660	P2-780	P2-900
19	.042 (1.07 mm)	ID	.424 (10.77 mm)	.549 (13.94 mm)	.674 (17.12 mm)	.799 (20.29 mm)	.924 (23.47 mm)
		PLUG	P2-420	P2-540	P2-660	P2-800	P2-920
20	.035 (.89 mm)	ID	.437 (11.10 mm)	.562 (14.27 mm)	.687 (17.45 mm)	.812 (20.62 mm)	.937 (23.80 mm)
		PLUG	P2-440	P2-560	P2-680	P2-800	P2-940
21	.032 (.81 mm)	ID	.442 (11.23 mm)	.567 (14.40 mm)	.692 (17.58 mm)	.817 (20.75 mm)	.942 (23.93 mm)
		PLUG	P2-440	P2-560	P2-700	P2-820	P2-940
22	.028 (.71 mm)	ID	.450 (11.43 mm)	.575 (14.61 mm)	.700 (17.78 mm)	.825 (20.96 mm)	.950 (24.13 mm)
		PLUG	P2-440	P2-580	P2-700	P2-820	P2-940
23	.025 (.64 mm)	ID	.455 (11.56 mm)	.580 (14.73 mm)	.705 (17.91 mm)	.830 (21.08 mm)	.955 (24.26 mm)
		PLUG	P2-460	P2-580	P2-700	P2-820	P2-960
24	.022 (.56 mm)	ID	.460 (11.68 mm)	.585 (14.86 mm)	.710 (18.03 mm)	.835 (21.21 mm)	.960 (24.38 mm)
		PLUG	P2-460	P2-580	P2-700	P2-840	P2-960

NOTES:

- Heat exchanger tube ID's often vary between inlet & outlet side. More than one P2 size may be required.
- If there is no previous experience indicating the correct p2 size and the tube ID's cannot be measured it is recommended to have (2) consecutive P2 sizes on hand.

EXAMPLE: A feedwater heater with 3/4" x 14 BWG tubes is being plugged for the first time. EST recommends enough P2-600 plugs to seal every tube and approximately half that amount of P2-620.

TABLE 2 Plug Sizing

Pop-a-Plug II Kit	Plug Size	Min.	Max.	Min.	Max.	Pop-a-Plug II Kit	Plug Size	Min.	Max.	Min.	Max.
		(in)		(mm)				(in)		(mm)	
P2-400-Q	0.400	0.401	0.420	10.19	10.68	P2-1200-Q	1.200	1.201	1.220	30.51	31.00
P2-420-Q	0.420	0.421	0.440	10.69	11.19	P2-1220-Q	1.220	1.221	1.240	31.01	31.51
P2-440-Q	0.440	0.441	0.460	11.20	11.70	P2-1240-Q	1.240	1.241	1.260	31.52	32.02
P2-460-Q	0.460	0.461	0.480	11.71	12.21	P2-1260-Q	1.260	1.261	1.280	32.03	32.53
P2-480-Q	0.480	0.481	0.500	12.22	12.72	P2-1280-Q	1.280	1.281	1.300	32.54	33.04
P2-500-Q	0.500	0.501	0.520	12.73	13.22	P2-1300-Q	1.300	1.301	1.320	33.05	33.54
P2-520-Q	0.520	0.521	0.540	13.23	13.73	P2-1320-Q	1.320	1.321	1.340	33.55	34.05
P2-540-Q	0.540	0.541	0.560	13.74	14.24	P2-1340-Q	1.340	1.341	1.360	34.06	34.56
P2-560-Q	0.560	0.561	0.580	14.25	14.75	P2-1360-Q	1.360	1.361	1.380	34.57	35.07
P2-580-Q	0.580	0.581	0.600	14.76	15.26	P2-1380-Q	1.380	1.381	1.400	35.08	35.58
P2-600-Q	0.600	0.601	0.620	15.27	15.76	P2-1400-Q	1.400	1.401	1.420	35.59	36.08
P2-620-Q	0.620	0.621	0.640	15.77	16.27	P2-1420-Q	1.420	1.421	1.440	36.09	36.59
P2-640-Q	0.640	0.641	0.660	16.28	16.78	P2-1440-Q	1.440	1.441	1.460	36.60	37.10
P2-660-Q	0.660	0.661	0.680	16.79	17.29	P2-1460-Q	1.460	1.461	1.480	37.11	37.61
P2-680-Q	0.680	0.681	0.700	17.30	17.80	P2-1480-Q	1.480	1.481	1.500	37.62	38.12
P2-700-Q	0.700	0.701	0.720	17.81	18.30	P2-1500-Q	1.500	1.501	1.520	38.13	38.62
P2-720-Q	0.720	0.721	0.740	18.31	18.81	P2-1520-Q	1.520	1.521	1.540	38.63	39.13
P2-740-Q	0.740	0.741	0.760	18.82	19.32	P2-1540-Q	1.540	1.541	1.560	39.14	39.64
P2-760-Q	0.760	0.761	0.780	19.33	19.83	P2-1560-Q	1.560	1.561	1.580	39.65	40.15
P2-780-Q	0.780	0.781	0.800	19.84	20.34	P2-1580-Q	1.580	1.581	1.600	40.16	40.66
P2-800-Q	0.800	0.801	0.820	20.35	20.84	P2-1600-Q	1.600	1.601	1.620	40.67	41.16
P2-820-Q	0.820	0.821	0.840	20.85	21.35	P2-1620-Q	1.620	1.621	1.640	41.17	41.67
P2-840-Q	0.840	0.841	0.860	21.36	21.86	P2-1640-Q	1.640	1.641	1.660	41.68	42.18
P2-860-Q	0.860	0.861	0.880	21.87	22.37	P2-1660-Q	1.660	1.661	1.680	42.19	42.69
P2-880-Q	0.880	0.881	0.900	22.38	22.88	P2-1680-Q	1.680	1.681	1.700	42.70	43.20
P2-900-Q	0.900	0.901	0.920	22.89	23.38	P2-1700-Q	1.700	1.701	1.720	43.21	43.70
P2-920-Q	0.920	0.921	0.940	23.39	23.89	P2-1720-Q	1.720	1.721	1.740	43.71	44.21
P2-940-Q	0.940	0.941	0.960	23.90	24.40	P2-1740-Q	1.740	1.741	1.760	44.22	44.72
P2-960-Q	0.960	0.961	0.980	24.41	24.91	P2-1760-Q	1.760	1.761	1.780	44.73	45.23
P2-980-Q	0.980	0.981	1.000	24.92	25.42	P2-1780-Q	1.780	1.781	1.800	45.24	45.74
P2-1000-Q	1.000	1.001	1.020	25.43	25.92	P2-1800-Q	1.800	1.801	1.820	45.75	46.24
P2-1020-Q	1.020	1.021	1.040	25.93	26.43	P2-1820-Q	1.820	1.821	1.840	46.25	46.75
P2-1040-Q	1.040	1.041	1.060	26.44	26.94	P2-1840-Q	1.840	1.841	1.860	46.76	47.26
P2-1060-Q	1.060	1.061	1.080	26.95	27.45	P2-1860-Q	1.860	1.861	1.880	47.27	47.77
P2-1080-Q	1.080	1.081	1.100	27.46	27.96	P2-1880-Q	1.880	1.881	1.900	47.78	48.28
P2-1100-Q	1.100	1.101	1.120	27.97	28.46	P2-1900-Q	1.900	1.901	1.920	48.29	48.78
P2-1120-Q	1.120	1.121	1.140	28.47	28.97	P2-1920-Q	1.920	1.921	1.940	48.79	49.29
P2-1140-Q	1.140	1.141	1.160	28.98	29.48	P2-1940-Q	1.940	1.941	1.960	49.30	49.80
P2-1160-Q	1.160	1.161	1.180	29.49	29.99	P2-1960-Q	1.960	1.961	1.980	49.81	50.31
P2-1180-Q	1.180	1.181	1.200	30.00	30.50	P2-1980-Q	1.980	1.981	2.000	50.32	50.82
						P2-2000-Q	2.000	2.001	2.020	50.83	51.32

Pop-a-plug II kits contain (10) plugs, a tube preparation brush and a Go/No-Go gage. The suffix "Q" in the P2 kit part number is the plug material designator. Please replace "Q" with one of the following:

A for 4142 alloy
 B for Brass
 C for Carbon Steel
 E for 304 Stainless
 M for Monel
 N for 90/10 Copper Nickel
 S for 316 Stainless
 T for Titanium

Plug material must match the tube material.

TABLE 3 Pull Rod Assemblies and Components Required for P2 Installation.

Installation Equipment

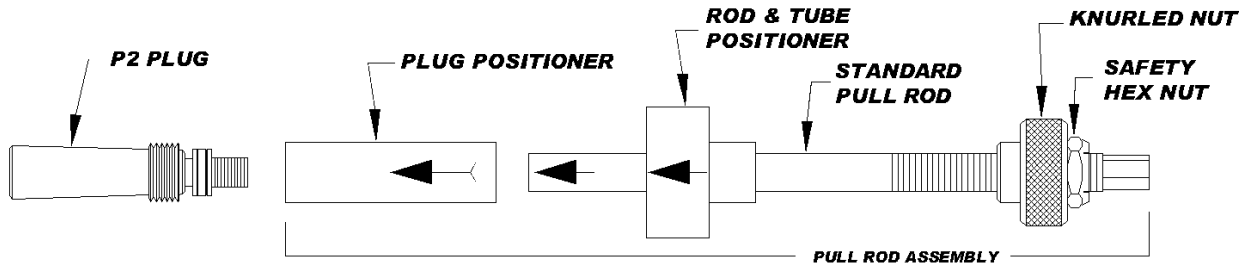

**NOTE: THE P2 PLUG SIZE IS STAMPED ON THE LARGE END OF THE PLUG.
 NEWER INSTALLATION EQUIPMENT IS STAMPED WITH THE P2 PLUG SIZE RANGE IT WILL INSTALL.
 OLDER INSTALLATION EQUIPMENT IS STAMPED WITH THE PART NUMBERS LISTED BELOW.**

INSTALLATION EQUIPMENT SMALL RAM										
P2 SIZE	POSITIONER		ROD & TUBE POSITIONER		PULL ROD		KNURLED NUT		PULL ROD ASSY	CHANNEL HEAD PULL ROD ASSY
.400-.440	PP-400-440		RTP-400-580		SPR-400-580		KN-400-580		PRA-400-440	CHA-400-440-LL
.460-.480	PP-460-500		RTP-400-580		SPR-400-580		KN-400-580		PRA-460-500	CHA-460-500-LL
.500-.580	PP-520-580		RTP-400-580		SPR-400-580		KN-400-580		PRA-520-580	CHA-520-580-LL
.600-.680	PP-600-680	+	RTP-600-860	+	SPR-600-860	+	KN-600-860	=	PRA-600-680	CHA-600-680-LL
.700-.780	PP-700-780		RTP-600-860		SPR-600-860		KN-600-860		PRA-700-780	CHA-700-780-LL
.800-.860	PP-800-860		RTP-600-860		SPR-600-860		KN-600-860		PRA-800-860	CHA-800-860-LL
.880-.960	PP-880-960		RTP-880-1160		SPR-880-1160		KN-880-1160		PRA-880-960	CHA-880-960-LL
.980-1.060	PP-980-1060		RTP-880-1160		SPR-880-1160		KN-880-1160		PRA-980-1060	CHA-980-1060-LL
1.080-1.160	PP-1080-1160		RTP-880-1160		SPR-880-1160		KN-880-1160		PRA-1080-1160	CHA-1080-1160-LL
INSTALLATION EQUIPMENT LARGE RAM										
P2 SIZE	POSIT		R&T POSIT		PULL ROD		KNURLED NUT		PULL ROD ASSY	CH HEAD PULL ROD ASSY
.400-.440	PP-400-440		LRTP-400-580		LPR-400-580		LKN-400-580		LPRA-400-440	LCHA-400-440-LL
.460-.480	PP-460-500		LRTP-400-580		LPR-400-580		LKN-400-580		LPRA-460-500	LCHA-460-500-LL
.500-.580	PP-520-580		LRTP-400-580		LPR-400-580		LKN-400-580		LPRA-520-580	LCHA-520-580-LL
.600-.680	PP-600-680		LRTP-600-860		LPR-600-860		LKN-600-860		LPRA-600-680	LCHA-600-680-LL
.700-.780	PP-700-780		LRTP-600-860		LPR-600-860		LKN-600-860		LPRA-700-780	LCHA-700-780-LL
.800-.860	PP-800-860		LRTP-600-860		LPR-600-860		LKN-600-860		LPRA-800-860	LCHA-800-860-LL
.880-.960	PP-880-960		LRTP-880-1160		LPR-880-1160		LKN-880-1160		LPRA-880-960	LCHA-880-960-LL
.980-1.060	PP-980-1060	+	LRTP-880-1160	+	LPR-880-1160	+	LKN-880-1160	=	LPRA-980-1060	LCHA-980-1060-LL
1.080-1.160	PP-1080-1160		LRTP-880-1160		LPR-880-1160		LKN-880-1160		LPRA-1080-1160	LCHA-1080-1160-LL
1.180-1.240	PP-1180-1240		LRTP-1180-2000		LPR-1180-2000		LKN-1180-2000		LPRA-1180-1240	LCHA-1180-1240-LL
1.260-1.340	PP-1260-1340		LRTP-1180-2000		LPR-1180-2000		LKN-1180-2000		LPRA-1260-1340	LCHA-1260-1340-LL
1.360-1.440	PP-1360-1440		LRTP-1180-2000		LPR-1180-2000		LKN-1180-2000		LPRA-1360-1440	LCHA-1360-1440-LL
1.460-1.540	PP-1460-1540		LRTP-1180-2000		LPR-1180-2000		LKN-1180-2000		LPRA-1460-1540	LCHA-1460-1540-LL
1.560-1.640	PP-1560-1640		LRTP-1180-2000		LPR-1180-2000		LKN-1180-2000		LPRA-1560-1640	LCHA-1560-1640-LL
1.660-1.740	PP-1660-1740		LRTP-1180-2000		LPR-1180-2000		LKN-1180-2000		LPRA-1660-1740	LCHA-1660-1740-LL
1.760-1.840	PP-1760-1840		LRTP-1180-2000		LPR-1180-2000		LKN-1180-2000		LPRA-1760-1840	LCHA-1760-1840-LL
1.860-1.940	PP-1860-1940		LRTP-1180-2000		LPR-1180-2000		LKN-1180-2000		LPRA-1860-1940	LCHA-1860-1940-LL
1.960-2.000	PP-1960-2000		LRTP-1180-2000		LPR-1180-2000		LKN-1180-2000		LPRA-1960-2000	LCHA-1960-2000-LL